

PS636 Series
Electric
Domestic & Std. Export
ENGLISH

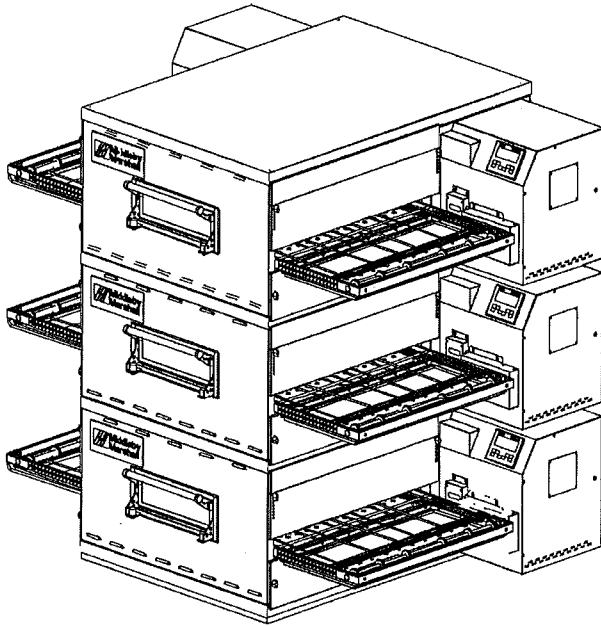

PN
April 2013



PS636 Series Electric Oven

Model:

- PS636E

Combinations:

- Single Oven
- Double Oven (Two-Stack)
- Triple Oven (Three-Stack)

OWNER'S OPERATING AND INSTALLATION MANUAL

for domestic and standard export ovens

©2007 Middleby Marshall Inc.



is a registered trademark of Middleby Marshall, Inc. All rights reserved.

Middleby Cooking Systems Group • 1400 Toastmaster Drive • Elgin, IL 60120 • (847)741-3300 • FAX (847)741-4406



NOTICE:

- This Owner's Operating and Installation Manual should be given to the user. The operator of the oven should be familiar with the operation of the oven.
- This manual must be kept in a prominent, easily reachable location near the oven.
- It is suggested to obtain a service contract with a Middleby Marshall Authorized Service Agent.

WARNING

FOR YOUR SAFETY, DO NOT STORE OR USE GASOLINE OR OTHER FLAMMABLE VAPORS AND LIQUIDS IN THE VICINITY OF THIS OR ANY OTHER APPLIANCE.

WARNING

Improper installation, adjustment, alteration service or maintenance can cause property damage, injury or death. Read the installation, operation and maintenance instructions thoroughly before installing or servicing this equipment.

IMPORTANT

An electrical wiring diagram for the oven is located inside the machinery compartment of the oven.

IMPORTANT

It is the customer's responsibility to report any concealed or non-concealed damage to the freight company. Retain all shipping materials until it is certain that the equipment has not suffered concealed shipping damage.

NOTICE

CONTACT YOUR MIDDLEBY MARSHALL AUTHORIZED SERVICE AGENT TO INSTALL AND PERFORM MAINTENANCE AND REPAIRS. AN AUTHORIZED SERVICE AGENT DIRECTORY IS SUPPLIED WITH YOUR OVEN.

NOTICE

Using any parts other than genuine Middleby Marshall factory manufactured parts relieves the manufacturer of all warranty and liability.

NOTICE

Middleby Marshall (Manufacturer) reserves the right to change specifications at any time.

NOTICE

The equipment warranty is NOT VALID unless the oven is installed, started and demonstrated under the supervision of a factory certified installer.

NOTICE

THIS EQUIPMENT IS FOR PROFESSIONAL USE AND SHALL BE USED BY QUALIFIED PERSONNEL.

RETAIN THIS MANUAL FOR FUTURE REFERENCE.

Model No. _____
Modèle No. _____

Serial No. _____
Sérié No. _____

Installation Date _____
Date d'installation _____

**MIDDLEBY MARSHALL
NO QUIBBLE LIMITED WARRANTY
(U.S.A. ONLY)**

MIDDLEBY MARSHALL, HEREINAFTER REFERRED TO AS "THE SELLER", WARRANTS EQUIPMENT MANUFACTURED BY IT TO BE FREE FROM DEFECTS IN MATERIAL AND WORKMANSHIP FOR WHICH IT IS RESPONSIBLE. THE SELLER'S OBLIGATION UNDER THIS WARRANTY SHALL BE LIMITED TO REPLACING OR REPAIRING, AT SELLER'S OPTION, WITHOUT CHARGE, ANY PART FOUND TO BE DEFECTIVE AND ANY LABOR AND MATERIAL EXPENSE INCURRED BY SELLER IN REPAIRING OR REPLACING SUCH PART. SUCH WARRANTY SHALL BE LIMITED TO THE ORIGINAL PURCHASER ONLY AND SHALL BE EFFECTIVE FOR A PERIOD OF ONE YEAR FROM DATE OF ORIGINAL INSTALLATION, OR 18 MONTHS FROM DATE OF PURCHASE, WHICHEVER IS EARLIER, PROVIDED THAT TERMS OF PAYMENT HAVE BEEN FULLY MET.

This warranty is valid only if the equipment is installed, started, and demonstrated under the supervision of a factory-authorized installer.

Normal maintenance functions, including lubrication, cleaning, or customer abuse, are not covered by this **no quibble warranty**.

Seller shall be responsible only for repairs or replacements of defective parts performed by Seller's authorized service personnel. Authorized service agencies are located in principal cities throughout the contiguous United States, Alaska, and Hawaii. This warranty is valid in the 50 United States and is void elsewhere unless the product is purchased through Middleby International with warranty included.

The foregoing warranty is exclusive and in lieu of all other warranties, expressed or implied. There are no implied warranties of merchantability or of fitness for a particular purpose.

The foregoing shall be Seller's sole and exclusive obligation and Buyer's sole and exclusive remedy for any action, including breach of contract or negligence. In no event shall Seller be liable for a sum in excess of the purchase price of the item. Seller shall not be liable for any prospective or lost profits of Buyer.

This warranty is effective on Middleby Marshall equipment sold on, or after, February 15, 1995.

**MIDDLEBY MARSHALL INC.
OVEN LIMITED WARRANTY
(Non U.S.A.)**

The Seller warrants equipment manufactured by it to be free from defects in material and workmanship for which it is responsible. The Seller's obligation under this warranty shall be limited to replacing or repairing, at Seller's option, without charge, F.O.B. Seller's factory, any part found to be defective and any labor and material expense incurred by Seller in repairing or replacing such part. Such warranty is limited to a period of one year from date of original installation or 15 months from date of shipment from Seller's factory, whichever is earlier, provided that terms of payment have been fully met. All labor shall be performed during regular working hours. Overtime premium will be charged to the Buyer.

This warranty is not valid unless equipment is installed, started, and demonstrated under the supervision of a factory-authorized installer.

Normal maintenance functions, including lubrication, adjustment of airflow, thermostats, door mechanisms, microswitches, burners and pilot burners, and replacement of light bulbs, fuses and indicating lights, are not covered by warranty.

Any repairs or replacements of defective parts shall be performed by Seller's authorized service personnel. Seller shall not be responsible for any costs incurred if the work is performed by other than Seller's authorized service personnel.

When returning any part under warranty, the part must be intact and complete, without evidence of misuse or abuse, freight prepaid.

Seller shall not be liable for consequential damages of any kind which occur during the course of installation of equipment, or which result from the use or misuse by Buyer, its employees or others of the equipment supplied hereunder, and Buyer's sole and exclusive remedy against Seller for any breach of the foregoing warranty or otherwise shall be for the repair or replacement of the equipment or parts thereof affected by such breach.

The foregoing warranty shall be valid and binding upon Seller if and only if Buyer loads, operates and maintains the equipment supplied hereunder in accordance with the instruction manual provided to Buyer. Seller does not guarantee the process of manufacture by Buyer or the quality of product to be produced by the equipment supplied hereunder and Seller shall not be liable for any prospective or lost profits of Buyer.

THE FOREGOING WARRANTY IS EXCLUSIVE AND IN LIEU OF ALL OTHER EXPRESS AND IMPLIED WARRANTIES WHATSOEVER. SPECIFICALLY THERE ARE NO IMPLIED WARRANTIES OF MERCHANTABILITY OR OF FITNESS FOR A PARTICULAR PURPOSE.

The foregoing shall be Seller's sole and exclusive obligation and Buyer's sole and exclusive remedy for any action, whether in breach of contract or negligence. In no event shall seller be liable for a sum in excess of the purchase price of the item.

© 2003 - Middleby Marshall, A Middleby Company.
The Middleby Marshall logo is a registered trademark of Middleby Marshall, A Middleby Company.

Middleby Marshall Inc. • 1400 Toastmaster Drive • Elgin, Illinois 60120-9272 U.S.A. • (847) 741-3300 • FAX: (847) 741 4406

TABLE OF CONTENTS

	Page		Page
SECTION 1 – DESCRIPTION	1	SECTION 3 – FEATURES & OPERATION	13
I. OVEN USES	1	I. PS636 CONTROL KEYS.....	13
II. OVEN COMPONENTS	1	II. DISPLAY FEATURES	14
A. Conveyor Motor Drive	1	III. CONTROL FEATURES	15
B. Crumb Pans	1	IV. OPERATION	15
C. Conveyor	1	A. STARTING THE OVEN.....	15
D. End Plugs	1	B. ADJUSTING THE TEMPERATURE	15
E. Eyebrows	1	C. ADJUSTING THE BELT TIME	15
F. Window	1	D. TURNING OFF THE OVEN	15
G. Machinery Compartment Access Panel	1	E. ENERGY MANAGEMENT	16
H. Serial Plate	1	V. TROUBLESHOOTING GUIDE	17
I. Control Panel	1	SECTION 4 - MAINTENENCE	
J. Photo Cell	1	I. MAINTENENCE - DAILY	18
K. Gas Burner	1	II. MAINTENENCE - MONTHLY	19
L. Blowers	1	III. MAINTENENCE - EVERY THREE MONTHS	20
M. Air Fingers	1	IV. MAINTENENCE - EVERY SIX MONTHS	21
III. OVEN SPECIFICATIONS	2	V. KEY SPARE PARTS KIT	22
A. Dimensions	2	SECTION 5 - ELECTRICAL WIRING DIAGRAMS	
B. General Specifications	2	208-240 V, 50/60Hz, 1 Phase.....	23
C. Electrical Specifications for PS636 Gas Ovens	2		
D. Gas Orifice and Pressure Specifications for PS636 Gas Ovens	2		
SECTION 2 – INSTALLATION	3		
I. INSTALLATION KIT	4		
II. VENTILATION SYSTEM	5		
A. Requirements	5		
B. Recommendations	5		
C. Other Ventilation Concerns	5		
III. ASSEMBLY	6		
A. Base Pad, Legs, Casters	6		
B. Stacking	7		
C. Restraint Cable Installation	7		
D. Conveyor Installation	8		
IV. FINAL ASSEMBLY	8		
V. ELECTRICAL SUPPLY	9		
Connection	10		

NOTE

Wiring Diagrams are in Section 5 of this Manual.
The diagram for each oven is also on the lower
inner surface of its Control Console.

SECTION 1 – DESCRIPTION

I. OVEN USES

PS636 Series Ovens can be used to bake and/or cook a wide variety of food products, such as pizza, pizza –type products, cookies, sandwiches and others.

II. OVEN COMPONENTS – see Figure 1-1.

- A. **Conveyor Drive Motor:** Moves the conveyor.
- B. **Crumb Pans:** Catch crumbs and other materials that drop through the conveyor belt. One crumb pan is located at each end of the conveyor.
- C. **Conveyor:** Moves the food product through the oven.
- D. **End Plugs:** Allow access to the oven's interior.
- E. **Eyebrows:** Can be adjusted to various heights to prevent heat loss into the environment.
- F. **Window:** Allows the user to access food products inside the baking chamber.
- G. **Machinery Compartment Access Panel:** Allows access to the oven's interior and control components. No user serviceable parts are located in the machinery compartment.
- H. **Serial Plate:** Provides specifications for the oven that affect installation and operation. Refer to Section 2, [Installation](#) for details.
- I. **Control Panel:** Location of the operating controls for the oven. Refer to Section 3, [Operation](#), for details.
- J. **Photo Cell:** Turns oven On when beam is interrupted.

Not Shown:

- K. **Gas Burner (gas ovens):** Heat air, which is then projected to the air fingers by the blowers.
- L. **Blowers:** Project hot air from the burner or heating element to the air fingers.
- M. **Air Fingers:** Project streams of hot air onto the food product.

Figure 1-1. Oven Components

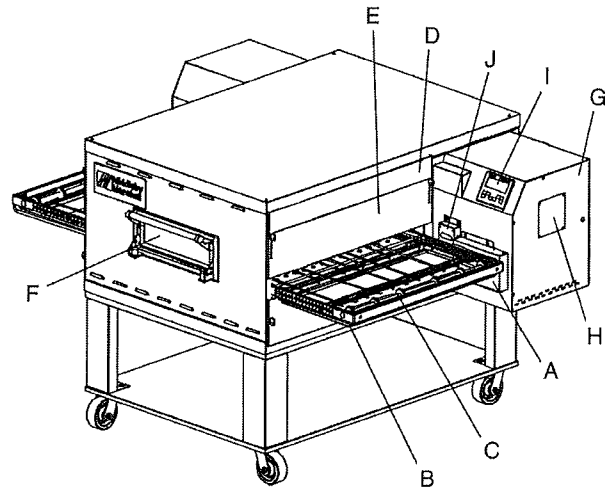

I. PS636E OVEN SPECIFICATIONS

Table 1 -1 Dimensions	Single Oven	Double Oven	Triple Oven
Overall Height	44" (1118 mm)	64-3/8" (1635 mm)	69-3/4" (1772 mm)
Overall Depth	44-1/2" (1130 mm)	44-1/2" (1130 mm)	44-1/2" (1130 mm)
Overall Length (w/o exit trays)	65-3/4" (1670 mm)	65-3/4" (1670 mm)	65-3/4" (1670 mm)
Conveyor Width (belt is 24")	25-1/2" (648 mm) or, 2 x 11" (279 mm)	25-1/2" (648 mm) or, 2 x 11" (279 mm)	25-1/2" (648 mm) or, 2 x 11" (279 mm)
Baking Area	6.0 sq. ft. (.557m ²)		

Recommended Minimum Clearances

Rear of Oven to Wall	0" (0 mm)	0" (0 mm)	0" (0 mm)
Control end of conveyor to wall	2" (50.8 mm)	2" (50.8 mm)	2" (50.8 mm)
Non-control end of conveyor to wall	2" (50.8 mm)	2" (50.8 mm)	2" (50.8 mm)

Table 1-2 General Specifications PS636E Electric Oven

Weight of Single Oven	734 lbs. (333 kg)
Max Operating Power	19.8 kW
Operating Temperature Range	350-600°F (177 - 316°C)
Warm-up Time	25 minutes
Belt Speed (Time)	0:30 – 20:00 (STD) 0:30 – 15:00 (SPECIAL)

Table 1-3 Electrical Specifications for PS636E electric ovens

DOMESTIC OVENS					
VOLTAGE	PHASE	HZ	kW	BREAKER	WIRING
208	3	50-60	19.8	70	4-WIRE / L1,L2,L3 & GROUND
240	3	50-60	19.8	60	4-WIRE / L1,L2,L3 & GROUND
INTERNATIONAL OVENS					
VOLTAGE	PHASE	HZ	kW	BREAKER	WIRING
208	3	50-60	19.8	70	4-WIRE / L1,L2,L3 & GROUND
240	3	50-60	19.8	60	4-WIRE / L1,L2,L3 & GROUND
380	3	50-60	19.8	40	5-WIRE / L1,L2,L3,N & GROUND
400-416	3	50-60	18.3 - 19.8	30	5-WIRE / L1,L2,L3,N & GROUND
230 (400 WYE)	3	50-60	18.2	30	5-WIRE / L1,L2,L3,N & GROUND

NOTE

Wiring Diagrams are contained in Section 5 of this manual and are also located inside the right hand oven control box.

Additional electrical information is provided on the oven's serial plate.

This manual must be kept for future reference.

PS636E-1 PS636E SINGLE OVEN

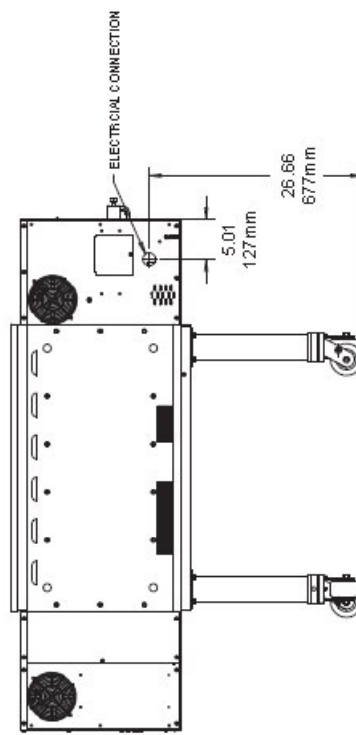
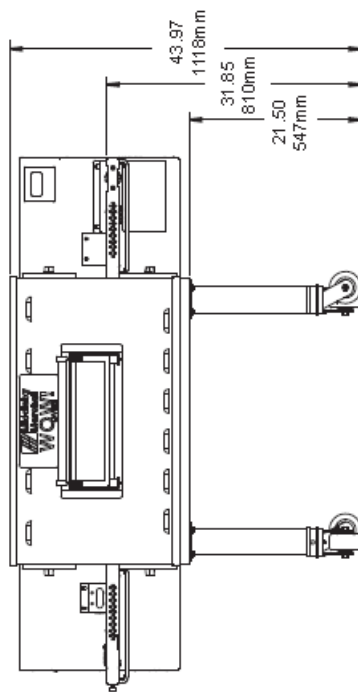
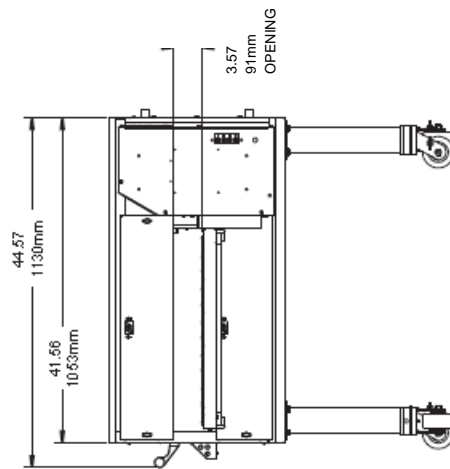
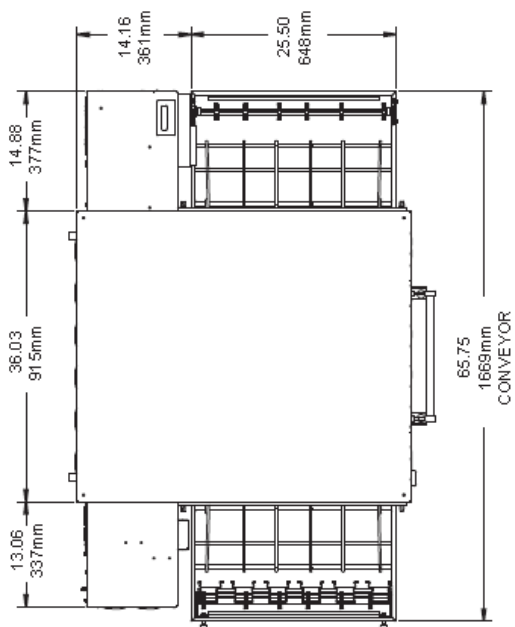

PS636E-2 PS636E DOUBLE OVEN

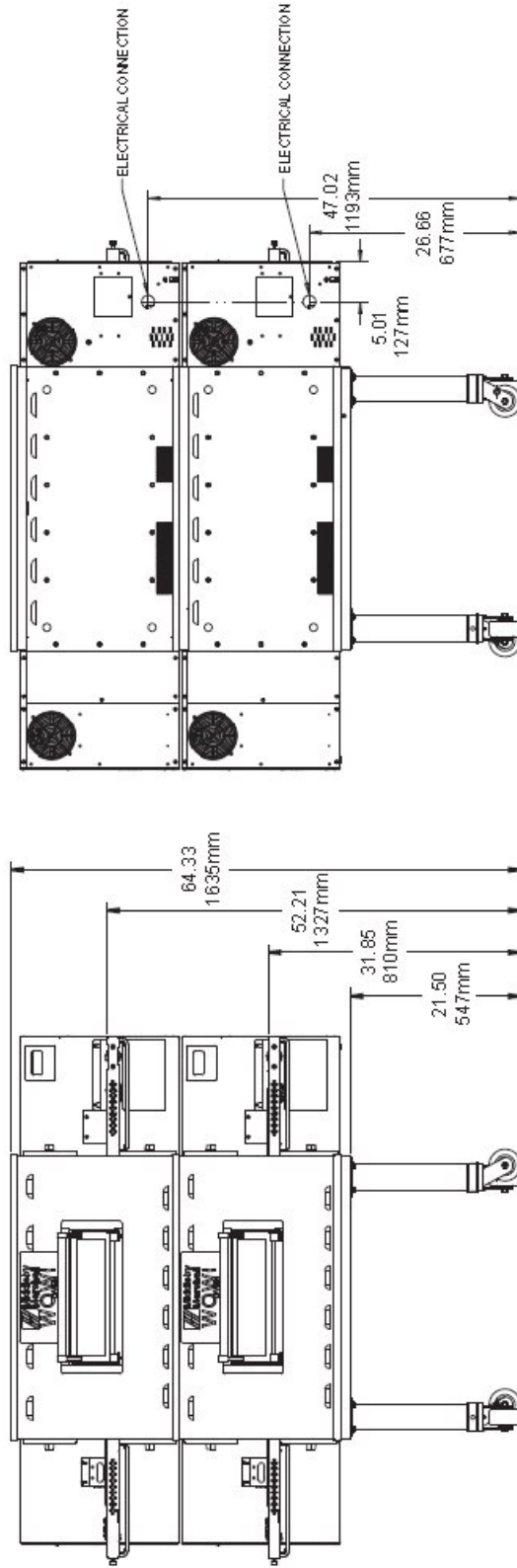

PS636E-3 PS636E TRIPLE OVEN

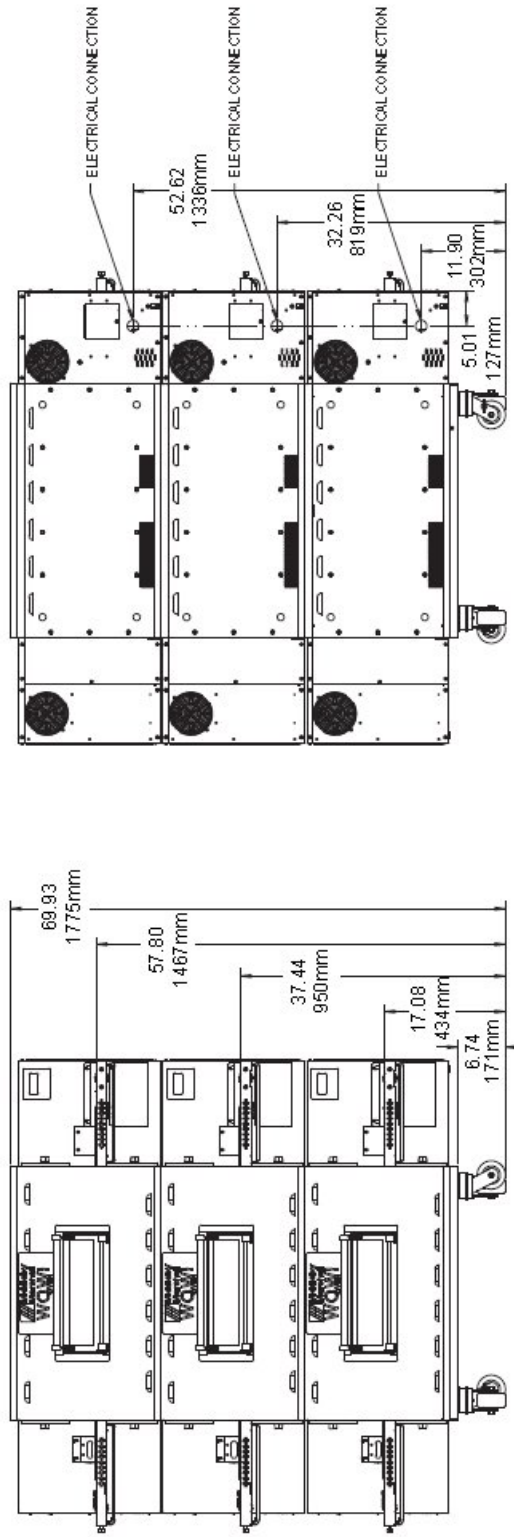

SECTION 2 INSTALLATION

WARNING

The oven must be installed on an even (level) non-flammable flooring and any adjacent walls must be non-flammable. Recommended minimum clearances are specified in the *Description* section of this Manual.

WARNING

Do not obstruct the flow of combustion and ventilation air to and from your oven. There must be no obstructions around or underneath the oven. Constructional changes to the area where the oven is installed shall not affect the air supply to the oven.

CAUTION

For additional installation information, contact your local Authorized Service Agent.

NOTE

There must be adequate clearance between the oven and combustible construction. Clearance must also be provided for servicing and for proper operation.

NOTE

An electrical wiring diagram for the oven is located inside the machinery compartment.

NOTE

All aspects of the oven installation, including placement, utility connections, and ventilation requirements, must conform with any applicable local, national, or international codes. These codes supersede the requirements and guidelines provided in this manual.

NOTE

In the USA, the oven installation must conform with local codes. Installed ovens must be electrically grounded in accordance with local codes, or in the absence of local codes, with the National Electrical Code (NEC), or ANSI/NFPA70.

NOTE - CANADA INSTALLATION

In Canada, the oven installation must conform with local codes. Installed ovens must be electrically grounded in accordance with local codes, or in the absence of local codes, with the Canadian Electrical Code CSA C22.2.

NOTE - AUSTRALIA INSTALLATION

In Australia, the oven installation must conform with any requirements of the appropriate statutory authority.

NOTE - CE OVEN INSTALLATION

Four casters are provided to allow the oven to be more easily moved to the installation location. These casters are intended to simplify pre-installation movement only, and are NOT suitable for use as part of a CE oven installation. During the installation procedure, the casters MUST be removed, so that the oven can be supported by the supplied 152mm adjustable legs.

NOTE - GROUNDING INSTRUCTIONS

The oven must be grounded. In the event of an electrical short circuit, grounding reduces the risk of electric shock by providing an escape wire or electric current. This product is equipped with a cord having a grounding wire and an appropriate grounding plug. This plug must be plugged into a properly installed outlet in accordance with all local codes and ordinances.

WARNING: *Improper installation of the grounding plug can result in the risk of electric shock. The grounding wire has insulation with an outer surface that is green with or without yellow stripes.*

Implementation of the grounding requirements should be carried out by a qualified electrician or service technician. Do not modify the appliance plug provided. If the appliance plug does not fit the outlet, the outlet should be replaced by a qualified electrician.

SECTION 2 INSTALLATION

NOTE: *The oven, when installed, must be electrically grounded in accordance with local codes, or in the absence of local codes, with the National Electrical Code (NEC), or ANSI/NFPA70.*

NOTE

There must be adequate clearance between the oven and any adjacent combustible construction. Clearance must also be provided for servicing and for operation.

CAUTION

It is recommended that the oven be placed under a ventilation hood for adequate air supply and ventilation.

CAUTION

Do not obstruct the flow of ventilation air to and from your oven. Do not obstruct the fan holes in the rear of the unit.

I. UNLOADING

Your Middleby Marshall PS636-Series Oven is shipped partially assembled. It will arrive in a carton on a crate.

The crate and carton must be examined before signing the Bill of Lading. Report any visible damage to the transport company, and check for the proper number of crates. If apparent damage is found, make arrangements to file a claim against the carrier. Surface Interstate Commerce Regulations (U.S.A.) require that the claim must be initiated by the consignee within 10 days from the date that the shipment is received.

Installer should be qualified to install commercial conveyor ovens, having suitable lifting equipment to prevent personal injury.

**PS636 24" OVEN INSTALLATION
REQUIRED KITS AND EQUIPMENT**

TYPE OF INSTALLATION	PS636 Gas Oven Installation Kit	PS636 Single Oven Option Base w/ 15" Legs, Casters & Top Kit P/N: 66955	PS636 Double Oven Option Base w/ 6" Legs, Casters & Top Kit P/N: 66956	PS636 Triple Oven Option Base w/ Casters & Top Kit P/N: 67280
PS636 Single	66331	1		
PS636 Double	66332	1	OPTION	
PS636 Triple	66333			1

**PARTS LIST FOR SERIES PS636 ELECTRIC OVEN
INSTALLATION KIT**

ITEM NO.	66331 QTY	66332 QTY	66333 QTY	PART NO.	DESCRIPTION
1	1	1	1	22450-0228	RESTRAINT CABLE
2	1	2	3	66241	LH CONTROL BOX GUARD
3	1	2	3	66244	RH CONTROL BOX GUARD

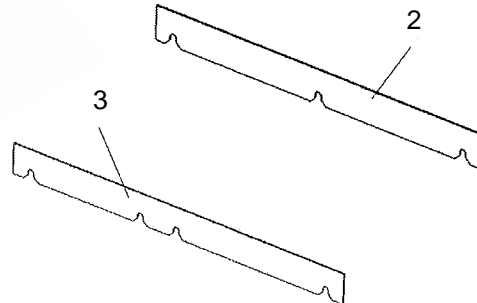
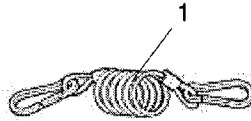

III. VENTILATION SYSTEM

IMPORTANT

Where national or local codes require the installation of fire suppression equipment or other supplementary equipment, **DO NOT** mount the equipment directly to the oven.

MOUNTING SUCH EQUIPMENT ON THE OVEN MAY:

- VOID AGENCY CERTIFICATIONS
- RESTRICT SERVICE ACCESS
- LEAD TO INCREASED SERVICE EXPENSES FOR THE OWNER

A. Requirements

CAUTION: Gas oven installations REQUIRE a mechanically driven ventilation system with electrical exhaust air sensing control.



A mechanically driven ventilation system is STRONGLY RECOMMENDED for electric oven installations.

PROPER VENTILATION OF THE OVEN IS THE RESPONSIBILITY OF THE OWNER.

B. Recommendations

NOTE THAT THE HOOD DIMENSIONS SHOWN IN FIGURE 2-5 ARE RECOMMENDATIONS ONLY. LOCAL, NATIONAL AND INTERNATIONAL CODES MUST BE FOLLOWED WHEN INSTALLING THE VENTILATION SYSTEM. ANY APPLICABLE CODES SUPERSEDE THE RECOMMENDATIONS SHOWN IN THIS MANUAL. IN AUSTRALIA COMPLIANCE TO REGULATIONS AS5601/AG601 IS MANDATORY.

The rate of air flow exhausted through the ventilation system may vary depending on the oven configuration and hood design. Consult the hood manufacturer or ventilation engineer for these specifications.

To avoid a negative pressure condition in the kitchen area, return air must be brought back to replenish the air that was exhausted. A negative pressure in the kitchen can cause heat-related problems to the oven components as if there were no ventilation at all. The best method of supplying return air is through the heating, ventilation and air conditioning (HVAC) system. Through the HVAC system, the air can be temperature-controlled for summer and winter. Return air can also be brought in directly from outside the building, but detrimental effects can result from extreme seasonal hot and cold temperatures from the outdoors.

NOTE: Return air from the mechanically driven system must not blow at the opening of the baking chamber. Poor oven baking performance will result.

C. Other ventilation concerns

- Special locations, conditions, or problems may require the services of a ventilation engineer or specialist.
- Inadequate ventilation can inhibit oven performance.
- It is recommended that the ventilation system and duct work be checked at prevailing intervals as specified by the hood manufacturer and/or HVAC engineer or specialist.

Figure 2-5. Ventilation System

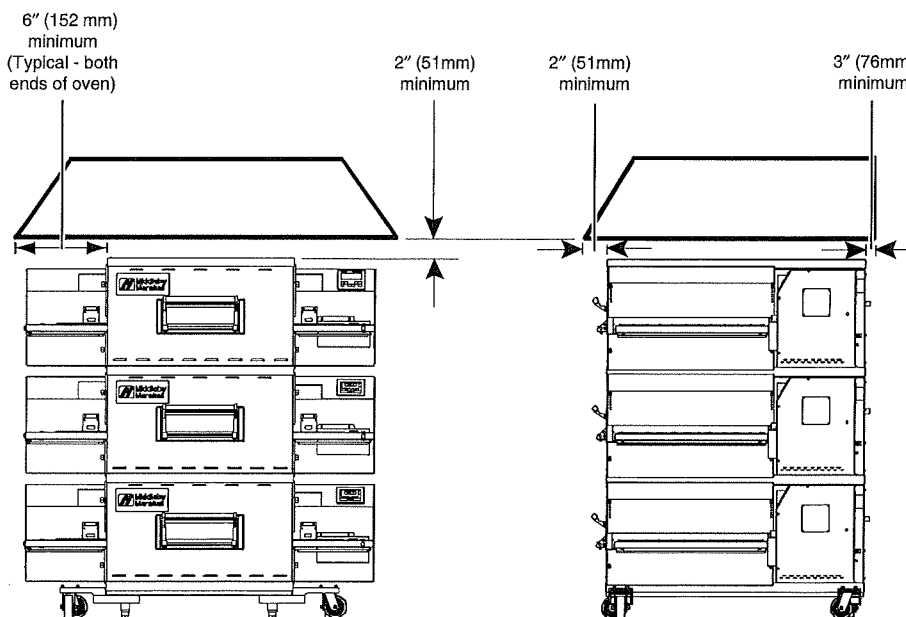

IV. ASSEMBLY

A. Top Panel and Base Pad Assembly

1. Install the four leg extensions onto the base pad using the 3/8"-16 x 1" screws, 3/8" flat washers, and 3/8" lockwashers supplied in the Base Pad Kit. See Figure 2-6. Check that the finished sides of each leg extension face OUTWARDS. One rear leg should be attached using three 3/8"-16 x 1" screws and the 3/4" eyebolt, as shown in Figure 2-6. This eyebolt acts as the anchor point for the restraint cable assembly (see Part C, Restraint Cable Installation).
2. If your oven is equipped with the lower shelf, position it in place as shown in Figure 2-6. Check that the lip on the shelf faces DOWN. Seal joint between leg and shelf with NSF listed silicone.
3. Install one caster onto each leg extension, as shown in Figure 2-7. Use the 3/8"-16 x 1" screws, 3/8" flat washers, and 3/8" lockwashers supplied in the Installation Kit. The locking casters should be installed at the FRONT of the oven. The non-locking casters should be installed at the REAR of the oven.
4. Install the lower oven cavity onto the base pad. See Fig 2-7.
5. For single ovens ONLY:
Install the top panel using the screws included in the base pad kit, as shown in Figure 2-8. Then, skip ahead to Part C, Restraint Cable Installation.

For double or triple ovens:

Continue on to Part B, Stacking. Note that the top panel should NOT be installed for double and triple ovens until after stacking the oven cavities.

Figure 2-6. Leg extension and casters installation

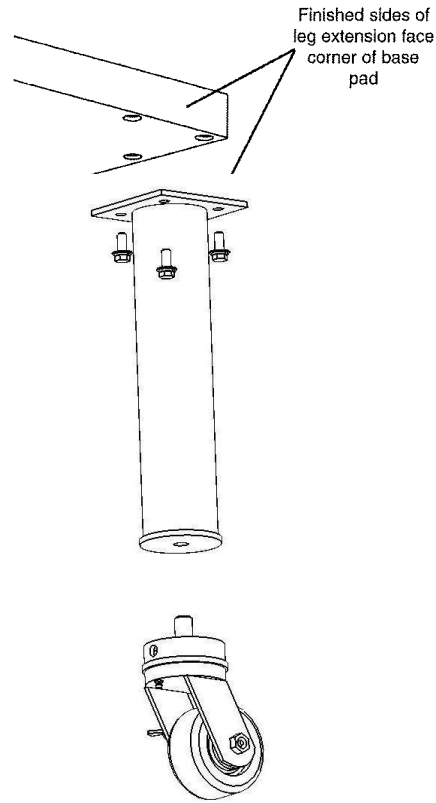

Figure 2-7. Base pad Installation

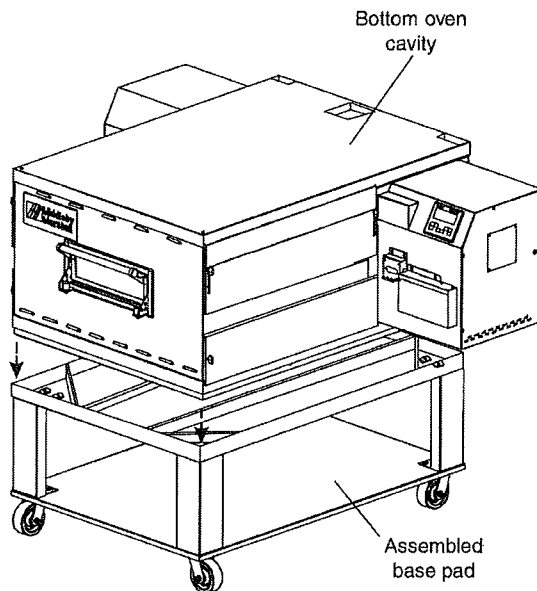
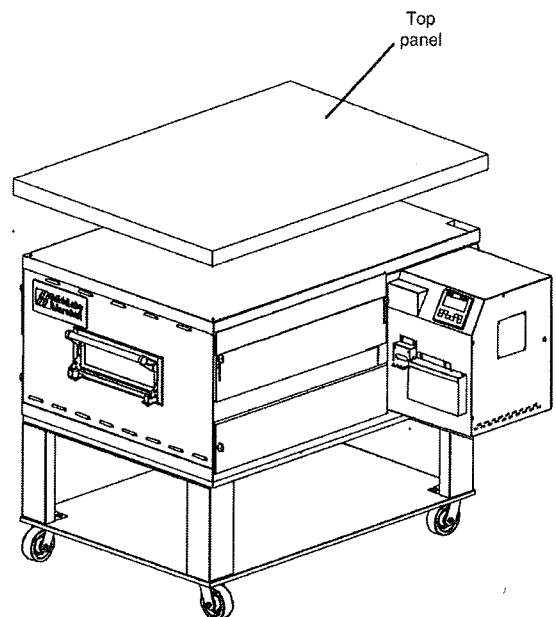

Figure 2-8. Top panel installation



NOTE: DO NOT install top panel onto double or triple ovens until AFTER stacking the oven cavities. See Part B, Stacking.

B. Stacking

For single ovens, skip ahead to Part C, Restraint Cable Installation.

IMPORTANT

Middleby Marshall **STRONGLY RECOMMENDS** that PS636 Gas oven cavities be stacked **BY AUTHORIZED PERSONEL**.

Contact your Middleby Marshall Authorized Service Agent for complete stacking instructions.

1. Stack an oven cavity on top of the lower oven. Check the following:
 - All four sides of the lower lip (on the bottom edge of the oven cavity) overlap the top of the lower oven
 - The oven is level
 - The oven is firmly seated
 See Figure 2-9.
2. For triple ovens, repeat Step 1 to install the top oven cavity.

Figure 2-9. Stacking

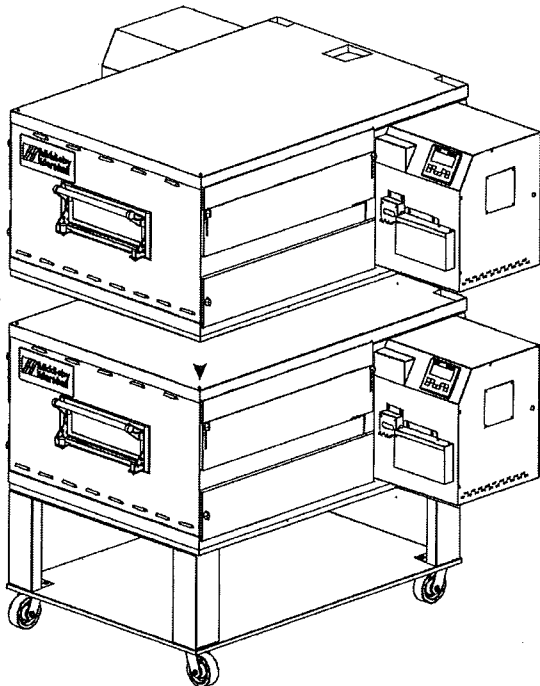

C. Restraint Cable Installation

Because the oven is equipped with casters, a restraint cable assembly must be installed to limit the movement of the appliance without depending on the connector and the quick disconnect device or its associated piping. One end of the cable is anchored to the eyebolt on the rear surface of the oven's base pad, while the other is anchored to the wall. See Figure 2-11. After connecting the restraint cable, move the oven to its final location. Adjust the bottom (hex) sections of the feet so that the casters are off the floor. For quad ovens, lock the two front casters.

Figure 2-10. Top panel installation

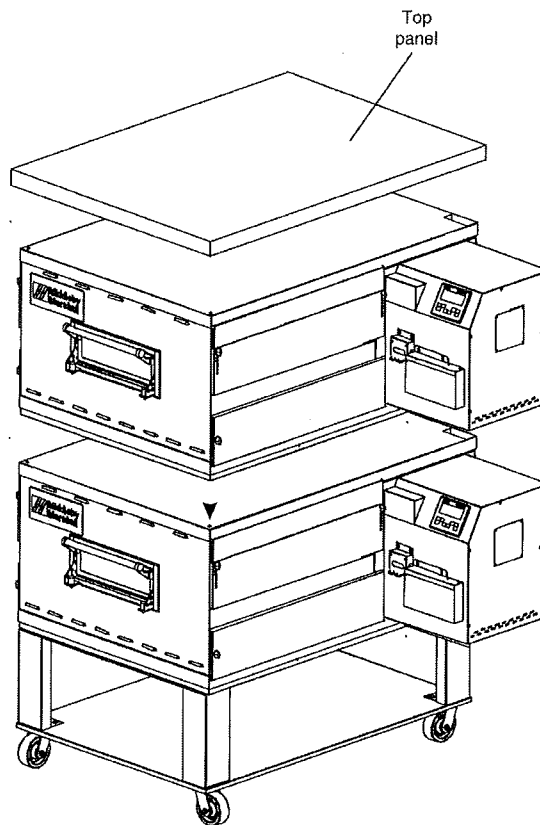
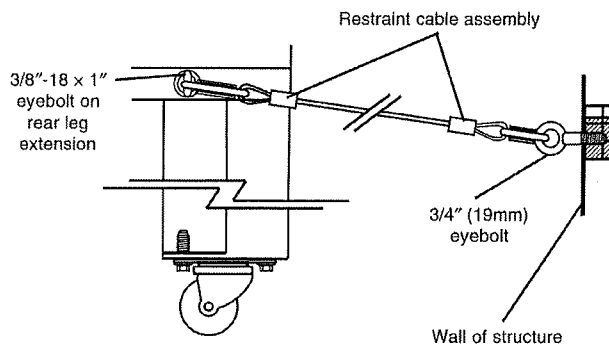

Figure 2-11. Installing the Restraint Cable



D. Conveyor Installation

1. Unfold the conveyor as shown in Figure 2-12. Then, begin to slide the conveyor into the end of the oven. The conveyor can only be installed from the end of the oven with the drive motor.
2. Continue moving the conveyor into the oven until the frame protrudes equally from each end of the oven. Check that the crumb tray supports located on the underside of the conveyor frame rest firmly against the lower end plugs, as shown in Figure 2-13.
3. When the conveyor is positioned properly, check for freedom of movement of the conveyor belt by pulling it for about 2-3 feet (0.6-1.0m) with your fingers. The drive and idler shafts must rotate smoothly, and the belt must move freely without rubbing on the inside of the oven.
4. Check the tension of the conveyor belt as shown in Figure 2-14. The belt should lift about 1" (25mm). **DO NOT OVERTIGHTEN THE CONVEYOR BELT.**

NOTE: If necessary, the belt tension can be adjusted by turning the conveyor adjustment screws, located at the idler (non-control) end of the conveyor. See Figure 2-14.

Figure 2-12. Conveyor installation

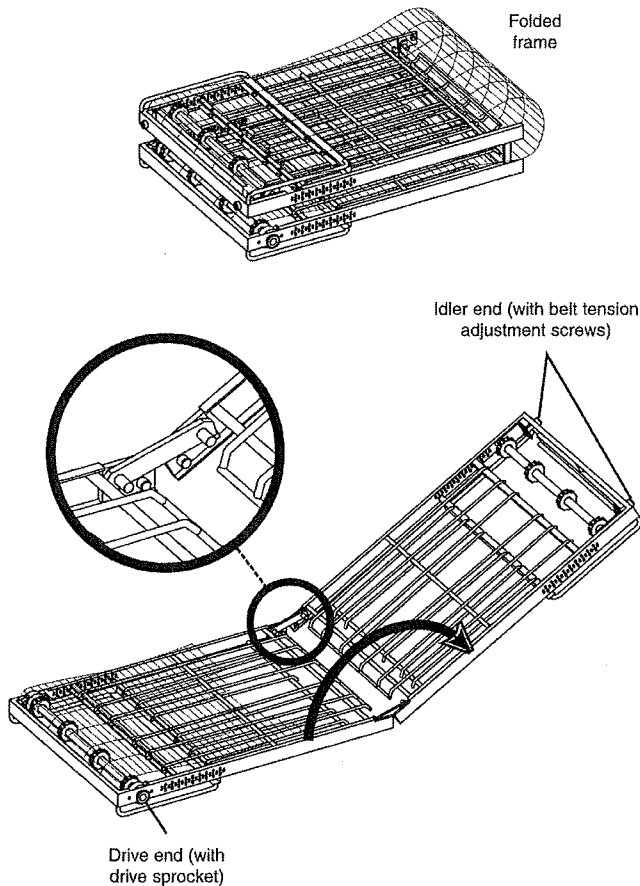

Figure 2-13. Conveyor placement

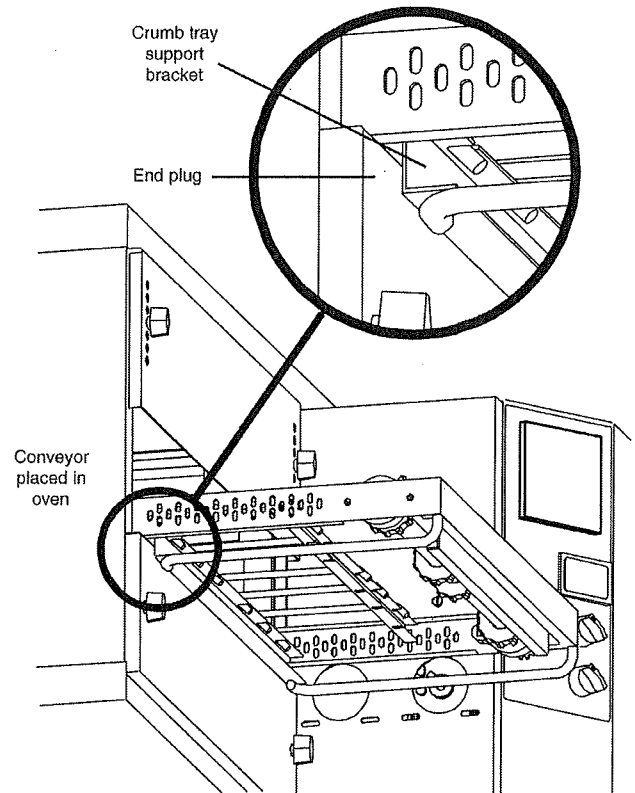
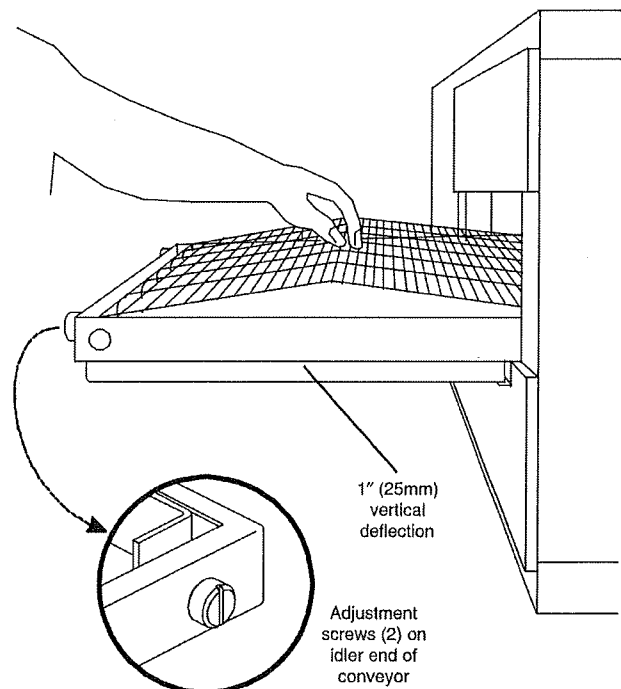
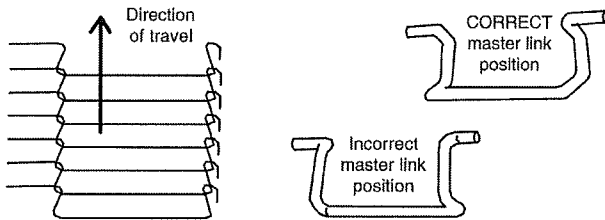

Figure 2-14. Conveyor Belt tension



5. If it is necessary to add or remove conveyor links to achieve the correct tension, OR if it is necessary to reverse the conveyor belt for correct orientation, the belt will need to be removed from the conveyor frame. If this is necessary, perform the following procedure:
 - Remove the conveyor assembly from the oven and place it flat on the floor.
 - Remove the master links using long-nose pliers. Then, roll up the belt along the length of the conveyor frame.
 - Add or remove belt links as necessary to achieve the correct belt tension.
 - Replace the belt on the conveyor frame. Check that the conveyor belt links are oriented as shown in Figure 2-15, and that the smooth side of the conveyor belt faces UP.
 - Connect the inside master links. Check that the links are oriented as shown in Figure 2-15.
 - Connect the outside master links. Note that the outside master links each have an open hook on one side. This hook aligns with the hooks along the sides of the other conveyor links. See Figure 2-15.
 - Replace the conveyor into the oven.

Figure 2-15. Conveyor and Master Link orientation



E. Final Assembly

1. Install the crumb trays underneath the conveyor as shown in Figure 2-16.

Figure 2-16. Crumb Trays

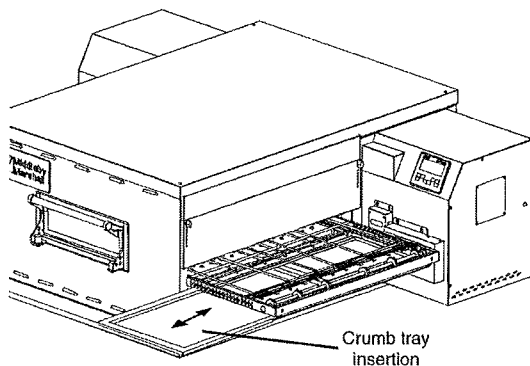

CONVEYOR BELT REVERSAL

Conveyor belt reversal consists of three steps:

1. Physically reversing the conveyor belt.
2. Resetting direction through the user interface.
3. Switching the photo detector.

REVERSING THE CONVEYOR BELT

Remove the conveyor from the oven and find the master link location. Remove master links and remove the belt from the conveyor frame. Reassemble the belt back onto the frame (in the reverse direction) and reinstall the master links. Replace the conveyor assembly in the oven.

RESETTING DIRECTION

See OVEN CONFIGURATION MENU in PS636G TECH SERVICE GUIDE. Direction is changed through the user interface with no wiring changes necessary.

CAUTION: Shock hazard in compartments electrical filters are electrically alive.



SWITCHING PHOTO DETECTOR

CAUTION: Disconnect Power Before Switching Photo eye.



Remove the three screws securing the access door to the unit. Open the access door and disconnect the connector fitting to the photo eye assembly. Remove the two screws securing the photo eye assembly to the control box. Remove the four nuts securing the photo eye to the housing. Rotate the photo eye 180 degrees and resecure the photo eye with the four nuts.

On the opposite control box, remove the two screws holding the cover where the photo eye assembly will be positioned. Secure the photo eye assembly in position with the two screws. Place the photo eye cover on the opposite control box, where the photo eye assembly was removed, and secure the two screws. Secure the access door with the three screws.

Remove the three screws securing the access door on the opposite side. Open the access door, where the photo eye is now positioned, and connect the photo eye connector fitting. Secure the access door with the three screws.

Apply power to the unit. Adjust the photo eye height by loosening the two screws securing the photo eye assembly and sliding the photo eye assembly either up or down, such that the beam is approximately 1/4 inch above the belt.

Note: This is MUCH easier in reduced light.

Replace all covers.

VI. ELECTRICAL SUPPLY

WARNING: Authorized installation personnel normally accomplish the connections for the ventilation system, electric supply, and gas supply, as arranged by the customer. Following these connections, the factory-authorized installer can perform the initial startup of the oven.



NOTE: The electric supply installation must satisfy the requirements of the appropriate statutory authority such as the National Electrical Code, CSA C22.2; the Australian Code AG601; or other applicable regulations.

NOTE: The electric supply connection must meet all national and local electrical code requirements.

Check the oven serial plate before making any electric supply connections. Electric supply connections must agree with data

Figure 2-17. Utility Connection Locations for Electric Oven

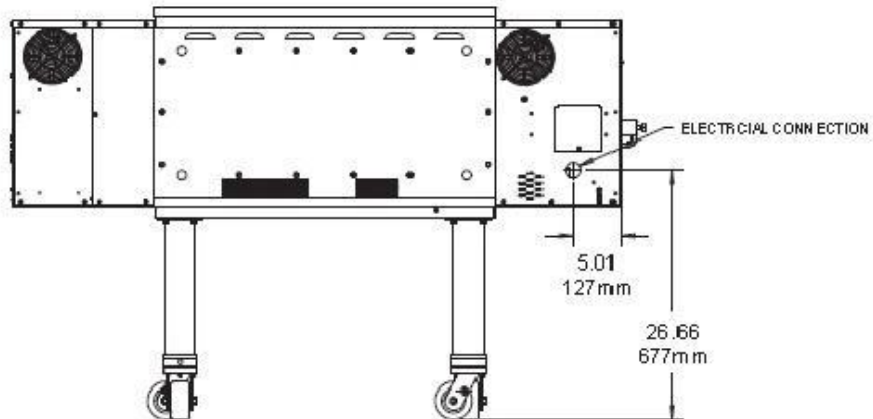

on the oven serial plate. The location of the serial plate is shown in Figure 1-1 (in Section 1, [Description](#)).

A fused disconnect switch or a main circuit breaker (customer furnished) **MUST** be installed in the electric supply line for each oven cavity. It is recommended that the switch/circuit breaker have Lockout/Tagout capability.

The supply conductors must be of the size and material (copper) recommended. Refer to the wiring diagram inside the machinery compartment of the oven. Electrical specifications are also listed on the oven's serial plate and in Table 1-3, [Electrical Specifications](#) (in Section 1, [Description](#)).

The oven requires a ground connection to the oven ground screw. For gas ovens, the screw is located in the electrical junction box (see Figure 2-14). If necessary, have the electrician supply the ground wire. *Do NOT use the wiring conduit or other piping for ground connections.*

Incoming electrical power lines are fed through the strain-relief fitting, shown in Figure 2-14. The electrical supply connections are made inside the electrical junction box. The power lines then connect to the oven circuits through safety switches located inside the machinery compartment and each blower motor compartment. These switches interrupt electrical power to the oven when the Machinery Compartment Access Panel is opened, OR when the rear panel is removed.

Connection

Refer to the wiring diagram inside the machinery compartment of the oven to determine the correct connections for the electrical supply lines. Connect the supply as indicated on the wiring diagram.

CAUTION: *The terms of the oven's warranty require all start-ups, conversions and service work to be performed by a Middleby Marshall Authorized Service Agent.*



**UTILITY ROUGH-IN DIMENSIONS AND POSITIONING
FOR PS636-SERIES OVENS**

WARNING
**DO NOT USE CONDUIT FOR
GROUND CONNECTION.**

CAUTION
**IT IS RECOMMENDED THAT THE OVEN
BE PLACED UNDER A VENTILATION
HOOD FOR ADEQUATE AIR SUPPLY
AND VENTILATION.**

**ELECTRIC SUPPLY TO BE
PROVIDED BY CUSTOMER**

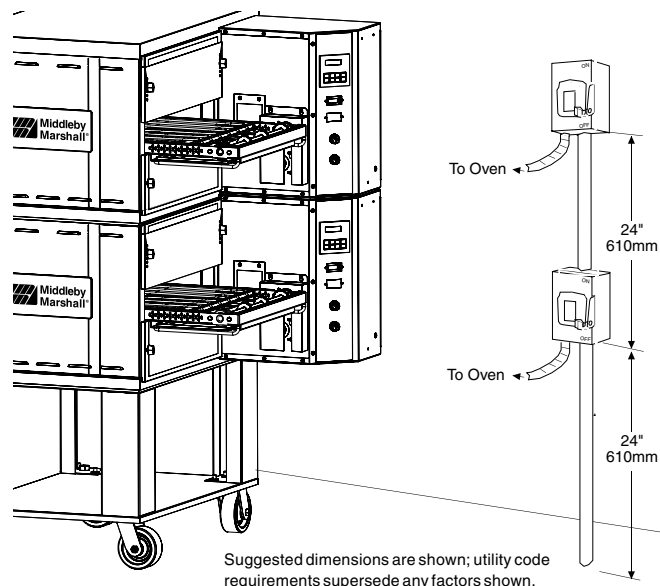

Figure 2-9. Typical Oven Installation

CIRCUIT BREAKER

A separate circuit breaker with lockout/tagout electrical shutoff is required for each, separately wired oven.

See breaker sizing requirements below:

ELECTRICAL SPECIFICATIONS

NOTE: Please refer to page 2, Electrical Specifications chart and your units data plate information, for more detailed information.

DOMESTIC:

4-WIRE SYSTEM (L1,L2, L3 & GROUND)

208V, 60 Hz, 19.8 kW, 70A Service

240V, 60 Hz, 19.8 kW, 60A Service

Do NOT use conduit for ground.

or

EXPORT: CE MODEL

4-WIRE SYSTEM (L1,L2, L3 & GROUND)

208V, 50/60 Hz, 19.8 kW, 30A Service

230-240V, 50/60Hz, 18.2/19.8 kW, 30A Service

5-WIRE SYSTEM (L1, L2, L3, N & GROUND)

380V, 50/60 Hz, 19.8 kW, 40A Service

400-416V, 50/60 Hz, 18.3-19.8 kW, 30A Service

230V (400Y), 50/60 Hz, 18.2 kW, 30A Service

Do NOT use conduit for ground.

POWER RATING

19.8 kW Standard

SUPPLY WIRE

Supply wire size must be in accordance with the National Electrical Code (current edition) and must be in compliance with local codes.

SUGGESTED

If space permits, service should be located near the control console end of the oven(s) to allow convenient access to safety switches.

II. VENTILATION GUIDELINES

Use of a ventilation hood is not required for proper operation, but installation must conform with all local codes and regulations.

Local codes and conditions vary greatly from one area to another and must be complied with. Following are the suggested requirements for good ventilation. Please remember these are recommendations or guidelines, you may have a special condition or problem that will require the services of a ventilation engineer or specialist. Proper ventilation is the oven owner's responsibility. Improper ventilation can inhibit oven performance.

SECTION 2
INSTALLATION

III. ELECTRICAL CONNECTION INFORMATION
FOR PS624-SERIES OVENS.

WARNING

Authorized supplier personnel normally accomplish the connections for the ventilation system, electric and gas supplies, as arranged by the customer. Following these connections, the factory-authorized installer can perform the initial startup of the oven.

Check the oven data plate (Figure 2-10) before making any electric supply connections. Electric supply connections must agree with data on the oven data plate.

NOTE: The electric supply installation must satisfy the requirements of the appropriate statutory authority, such as the National Electrical Code (NEC), ANSI/NFPA70, (U.S.A.); the Canadian Electrical Code, CSA C22.2; the Australian Code AG601; or other applicable regulations.

A fused disconnect switch or a main circuit breaker (customer furnished) **MUST** be installed in the electric supply line for each oven; it is recommended that this switch/circuit breaker have lockout/tagout capability. The electric supply connection must meet all national and local electrical code requirements. Copper is the recommended material for the electrical supply conductors.

IV. ELECTRIC SUPPLY

Electrical connection is a fixed conduit connection. See Electrical Specifications chart on page 2.

The supply conductors must be of the size and material (copper) recommended to provide the current required; (refer to the data plate for the ampere specifications).

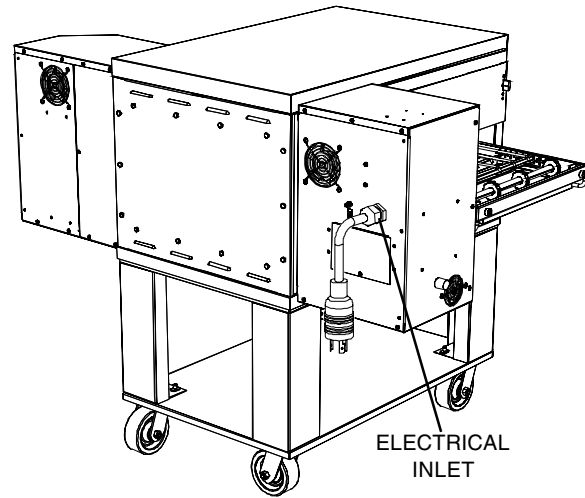

Figure 2-11. Junction Connection Box

<p>MIDDLEBY MARSHALL 1400 TOASTMASTER DRIVE ELGIN ILLINOIS 60120 USA</p>					
MOD., TYP		SR.-NR:		ANNO	
		ID.-NR:			
IT,PT,ES,SE,GB CH,IE,AT,DK,FI,CR	NL	LU, DE	BE,FR	SE,CH,AT,DK,NO FI,DE,NL,CR,FR	BE,IE,IT,FR PT,ES,CH,GB
CAT	I2H	I2L	I2E	I2E+	I3B/P
P	G20 20	G25 25	G20 20	G20 20/25	G30 28-30/50
<p>Qn = kW _____</p> <p>U = V _____</p> <p>A = A _____</p> <p>Hz ~ _____</p> <p>TYPE A</p>					
0359					
<p>THIS APPLIANCE IS FOR PROFESSIONAL USE AND SHALL BE USED BY QUALIFIED PEOPLE</p>					
P/N 45838 REV G					

International CE Plate

MODEL NO.	SERIAL NO.
Numero de modele	Numero de serie
ID NO.	
VAC	AMP
Tension	Intensité
100 TYP.	L1 L2 L3 N
160 FLCS.	PH WIRE
KW	Phase
HZ	Cablage
MOTOR VOLTS	PH
Moteur Volts	Phase
	AMP
	Intensité
<p>DO NOT INSTALL CLOSER THAN _____ INCHES TO A NON-COMBUSTIBLE BACK WALL, AND _____ INCHES TO NON-COMBUSTIBLE SIDE WALLS ONLY. FOR INSTALLATION ON COMBUSTIBLE FLOORS ADJACENT TO COMBUSTIBLE WALLS WITH FOLLOWING MINIMUM CLEARANCES:</p> <p>_____ INCHES RIGHT SIDE WALL. _____ INCHES TO LEFT WALL.</p> <p>_____ INCHES TO BACK WALL.</p>	
<p>N'INSTALLEZ PAS À MOINS DE _____ PO D'UN PANNEAU ARRIERE INCOMBUSTIBLE ET À _____ PO DE PANNEAUX LATÉRAUX INCOMBUSTIBLES UNIQUEMENT. DESTINÉ A UN USAGE AUTRE QUE DOMESTIQUE. INTENDED FOR OTHER THAN HOUSEHOLD USE.</p>	
<p>1400 TOASTMASTER DRIVE ELGIN, ILLINOIS 60120, U.S.A.</p>	
58305 REV B	

Domestic Plate

Figure 2-10. Typical Electric Oven Data Plate

SECTION 3 - FEATURES & OPERATION

PS636 CONTROL KEYS

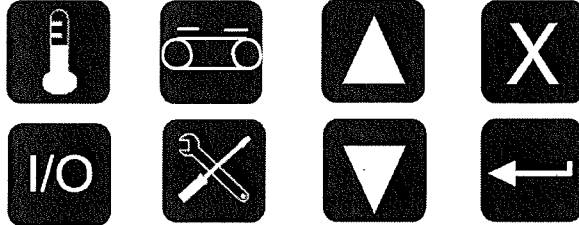

"ON/OFF" KEY: > QUICK PRESS BRINGS OVEN TO ACTIVE, "ON" MODE.

> PRESS & HOLD WILL PUT OVEN INTO "OFF" MODE.
IF TEMP IS OVER 200F THE BLOWERS WILL REMAIN
ON UNTIL THE OVEN TEMP DROPS BELOW 200F.



"TEMPERATURE" KEY: > QUICK PRESS DISPLAYS ACTUAL TEMPERATURE.

> PRESS & HOLD UNTIL DISPLAY FLASHES. ALLOWS
CHANGE TO SET TEMPERATURE.



"BELT" KEY: > QUICK PRESS DISPLAYS ALTERNATE FRONT AND BACK BELT SPEEDS.

> PRESS & HOLD UNTIL DISPLAY FLASHES. ALLOWS
CHANGE TO BELT SPEED.



"UP/DOWN" KEYS: > PRESS UP OR DOWN TO CHANGE NUMBER VALUES OR
CHANGE PARAMETER.



"TOOLS" KEY: PRESS (WHEN OFF) TO ENTER "SETUP" OR "TEST" SCREENS



"CANCEL" KEY: > QUICK PRESS CANCELS LAST ACTION & RETURNS TO
LAST SCREEN OR OPERATION.

> PRESS & HOLD TO SHUT OVEN OFF.



"RETURN" KEY: > QUICK PRESS STARTS OVEN FROM OFF MODE.

> ENTERS & SAVES CHANGED PARAMETER VALUE.

PS636G DISPLAY FEATURES

STATUS INDICATOR:

"BAKING" appears when the oven is in baking mode. No text here indicates that the oven is in IDLE mode

SETPOINT:

Set point (baking) temperature is displayed here.

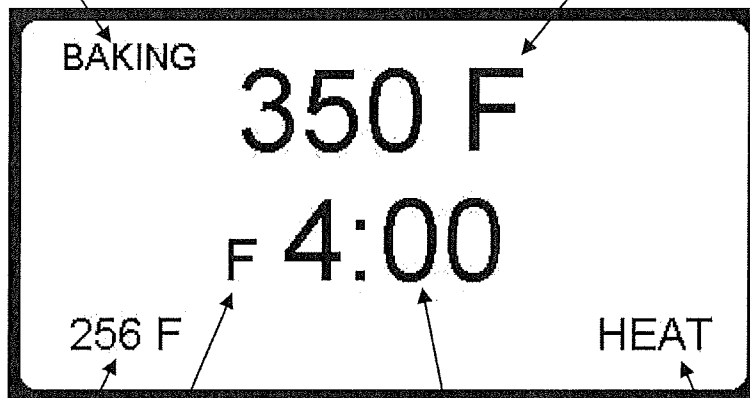

BELT DISPLAYED:

"F" indicates FRONT belt time is being displayed. "B" indicates that the BACK belt time is being displayed. If no letter appears the belt times are identical.

HEAT STATUS:

Alternating display indicates: "HEAT" - heat relay is energized "30 %" - "percent of heat" signal from the control to the gas valve

ACTUAL TEMPERATURE:

Actual temperature of the oven is displayed here. If it is not displayed, pressing the TEMPERATURE key momentarily will show the actual temperature for 15 seconds.

BELT SPEED:

Displays time in minutes and seconds that it takes for the belt to travel the length of the baking chamber.

CONTROL FEATURES

The PS636G control performs a variety of functions, including:





- Temperature control
- Belt speed control
- Upper/lower blower speed setting
- Energy management
- Oven diagnostics & system testing
- Conveyor speed calibration

The oven control will have power delivered to it and initialize when the oven is connected to the power supply. Upon initialization, the control will briefly display its "WOW OVEN" splash screen, then proceed to OFF mode.





STARTING THE OVEN

To start the oven, press the  button. The oven will start and the operating display will appear on the screen. The blowers will begin and the blower proving switches will engage, permitting the heat circuit relay to engage. The gas ignition module will begin its cycle and ignite the three inshot burners.

ADJUSTING THE TEMPERATURE

To adjust the set temperature, press and hold the  button until the set temperature display flashes. Press the  or  arrow until the desired set temperature is displayed. Press the  button to set and save the new temperature value. If  button is not pressed, the new temperature will be present only until the oven is turned OFF. The previously used set temperature will appear when the oven is turned ON again.

ADJUSTING THE BELT TIME

To adjust the belt time, press and hold the  button until the belt time display flashes. Press the  or  button until the desired belt time is displayed. Press the  button to set and save the new time value. If the  button is not pressed, the new time will be present only until the oven is turned OFF. The previously used set temperature will appear when the oven is turned ON again.

If the belt times differ, the display will indicate the belt time with a letter (F or B) preceding the time to indicate FRONT or BACK conveyor belt. Pressing the  button momentarily will alternate the time display between the FRONT and BACK conveyor belt times. If the times are made the same, the time will be displayed without any letter in front of the time value.

TURNING THE OVEN OFF

To turn the oven OFF, press and hold the  button. If the oven is below 200°F the display will show "WOW OVEN" screen. If the oven is above 200°F, the display will show "COOL DOWN" and the blowers will run at a preset cool down speed until the oven temperature falls below 200° at which point the oven will go to the OFF mode. In the OFF mode, the screen will display the "WOW OVEN" screen for a one minute period after which the screen backlight will shut off. The oven will stay in this condition until it is started again, with no outputs energized.

ENERGY MANAGEMENT

The PS636 reduces energy usage in two ways over most competitive ovens:

- Modulating gas control
- IDLE / BAKING mode control (Energy Saving Mode)

The modulating gas valve within the oven controls pressure of the delivered gas to the burners to increase or reduce the energy input as needed to maintain temperature instead of cycling a gas valve on and off. This is a more efficient and accurate way of controlling the temperature and eliminates the losses associated with the ON/OFF cycling control.

The PS636 like other Middleby WOW ovens has an idle mode that places the blowers at a reduced speed during non-baking periods. Reducing the blower speed reduces the volume of air requiring heating and thus reduces energy usage in these non-baking times. A photo eye sensor at the entrance side of the baking chamber detects when food is placed on the belt and brings the oven up to the higher (baking) blower speed, increasing the amount of convection air needed to cook products faster. When the product passes the photo eye, the controller begins a preset timed period that insures the product will pass fully through the oven before the oven returns to the IDLE mode. With this energy management scheme, the oven provides the increased convection heat transfer needed for fast baking, without the energy penalty during non-baking times. This functionality is fully automatic and requires no user interaction.

III. TROUBLESHOOTING GUIDE

SYMPTOM	POSSIBLE CAUSES	SOLUTIONS
Nothing displayed on controller	<ol style="list-style-type: none"> 1. Power not connected 2. Main breaker not on 	<ol style="list-style-type: none"> 1. Check plug at wall 2. Check main breaker
Control display is dim and the WOW OVEN image can be seen	Control is in OFF/STANDBY mode.	No problem – the control backlight turns off when the oven is not turned on for use.
Oven not baking properly	<ol style="list-style-type: none"> 1. Settings have been changed 2. Kitchen airflow conditions affecting the bake 	<ol style="list-style-type: none"> 1. Confirm correct values and check that the oven is set properly (time and temperature) 2. Eliminate air cross-currents in area
Conveyor noticeably running at the wrong speed	Time settings have been changed	Confirm correct values and correct control settings
Conveyor not moving	<ol style="list-style-type: none"> 1. Something has jammed the conveyor 2. Circuit breaker (behind control panel) has tripped 	<ol style="list-style-type: none"> 1. Turn power off. Locate and remove jam item. 2. Contact service to check conveyor and reset the breaker.
“IGNITION LOCKOUT” on display	<ol style="list-style-type: none"> 1. Gas not turned on to oven 2. Burner has stopped running 	<ol style="list-style-type: none"> 1. Turn on manual valve on supply to oven 2. Turn the oven off and back on again to clear the notification and relight
“BAKING” indication goes on and off in upper left corner of the control display	Oven is cycling normally. BAKING indication comes on upon triggering the photo eye.	No problem – the timed baking cycle automatically starts when product breaks the photo eye beam and stops after product leaves the baking chamber.

NOTE: If the remedial measures above do not successfully resolve the issue, or the issue is not listed above, contact the Middleby Customer Care Center at 847-429-7817

SECTION 4 - MAINTENANCE

WARNING

Before ANY cleaning or servicing of the oven, perform the following procedure:

1. Switch off the oven and allow it to cool. Do NOT service the oven while it is warm.
2. Turn off the electric supply circuit breaker(s) and disconnect the electric supply to the oven.
3. If it is necessary to move a gas oven for cleaning or servicing, disconnect the gas supply before moving the oven.

When all cleaning and servicing is complete:

1. If the oven was moved for servicing, return the oven to its original location.
2. If the restraint cable was disconnected to clean or service the oven, reconnect it at this time.
3. Reconnect the gas supply.
4. Reconnect the electrical supply.
5. Turn on the full-flow gas safety valve. Test the gas line connections for leaks using approved leak test substances or thick soap suds.
6. Turn on the electric supply circuit breaker(s).
7. Perform the normal startup procedure.

WARNING

Possibility of injury from moving parts and electrical shock exists in this oven. Switch off and lockout/tagout the electric supply BEFORE beginning to disassemble, clean, or service any oven. Never disassemble or clean an oven with the BLOWER (⊗) switch or any other circuit of the oven switched on.

CAUTION

NEVER use a water hose or pressurized steam-cleaning equipment when cleaning this oven. To avoid saturating the oven insulation, DO NOT use excessive amounts of water. DO NOT use a caustic oven cleaner, which can damage the bake chamber surfaces.

NOTE

ANY replacement parts that require access to the interior of the oven may ONLY be replaced by a Middleby Marshall Authorized Service Agent. It is also strongly recommended that the 3-Month Maintenance and 6-Month Maintenance procedures in this section be performed ONLY by a Middleby Marshall Authorized Service Agent.

I. MAINTENANCE - DAILY

- A. Check that the oven is cool and the power is disconnected, as described in the warning at the beginning of this Section.
- B. Clean ALL of the cooling fan grills and vent openings with a stiff nylon brush. Refer to Figure 4-1 for the locations of the grills and vents.
- C. Clean the outside of the oven with a soft cloth and mild detergent.
- D. Check that ALL cooling fans are operating properly.

CAUTION: If a cooling fan is not operating correctly, it must be replaced IMMEDIATELY. Operating the oven without adequate cooling can seriously damage the oven's internal components.



- E. Clean the conveyor belts with a stiff nylon brush. This is more easily accomplished by allowing the conveyor to run while you stand at the exit end of the conveyor. Then, brush the crumbs off the conveyor as it moves.
- F. Remove and clean the crumb trays. If necessary, refer to Figure 2-16 (in Section 2, Installation) when replacing the crumb trays into the oven.
- G. Clean the window in place.

Figure 4-1. Cooling Vents and Grills

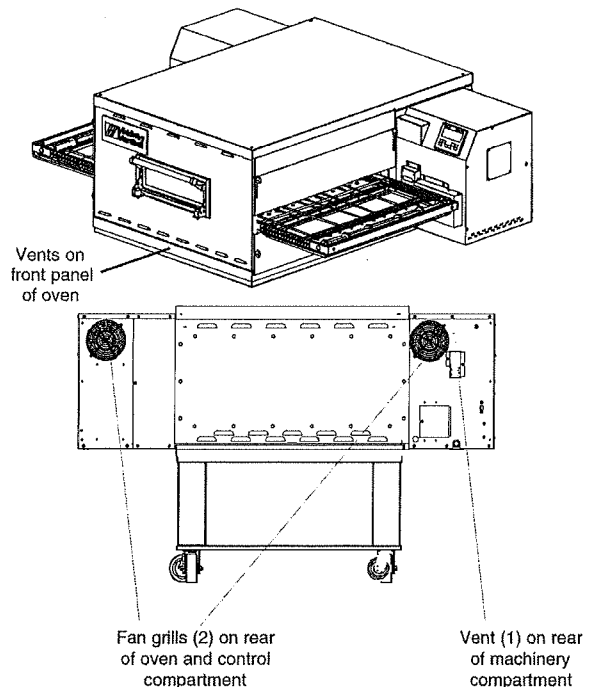

II. MAINTENANCE – MONTHLY

NOTE: When removing the conveyor, refer to Figure 2-12 (in Section 2, Installation).

- A. Check that the oven is cool and the power is disconnected, as described in the warning at the beginning of this Section.
- B. Remove the crumb trays from the oven.
- C. Lift the drive end of the conveyor slightly, and push it forward into the oven. This removes the tension from the drive chain. Then, remove the drive chain from the conveyor sprocket.
- D. Slide the conveyor out of the oven, folding it as it is removed.
- E. Remove the end plugs from the oven. The end plugs are shown in Figure 1-1 (in Section 1, Description).
- F. Slide the air fingers and blank plates out of the oven, as shown in Figure 4-2. **AS EACH FINGER OR PLATE IS REMOVED, WRITE A "LOCATION CODE" ON IT WITH A MARKER** to make sure that it can be reinstalled correctly.

Example of markings:

(Top Row)	T1	T2
(Bottom Row)	B1	B2

- G. Disassemble the air fingers as shown in Figure 4-3. **AS EACH FINGER IS DISASSEMBLED, WRITE THE "LOCATION CODE" FOR THE FINGER ON ALL THREE OF ITS PIECES.** This will help you in correctly reassembling the air fingers.

CAUTION: *Incorrect reassembly of the air fingers will change the baking properties of the oven.*



- H. Clean the air finger components and the interior of the baking chamber using a vacuum cleaner and a damp cloth. Refer to the boxed warnings at the beginning of this Section for cleaning precautions.
- I. Reassemble the air fingers. Then, replace them in the oven, using the "location guide" as a guide.
- J. Replace the end plugs on the oven.
- K. Reassemble the conveyor into the oven. If the drive sprocket was removed when installing the conveyor, replace it at this time.
- L. Reattach the drive chain.
- M. Check the tension of the conveyor belt as shown in Figure 2-14 (in Section 2, Installation). The belt should lift between 3 - 4" (75-100mm). **DO NOT OVERTIGHTEN THE CONVEYOR BELT.** If necessary, the belt tension can be adjusted by turning the conveyor adjustment screws, located at the idler (right) end of the conveyor.
- N. Replace the crumb trays.

Figure 4-2. Removing Air Fingers and Plates

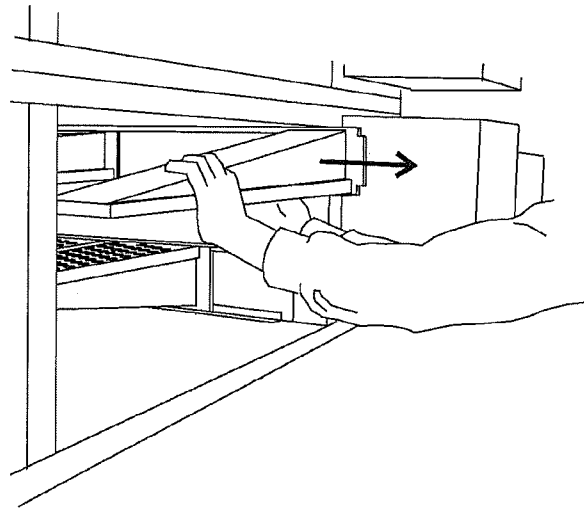
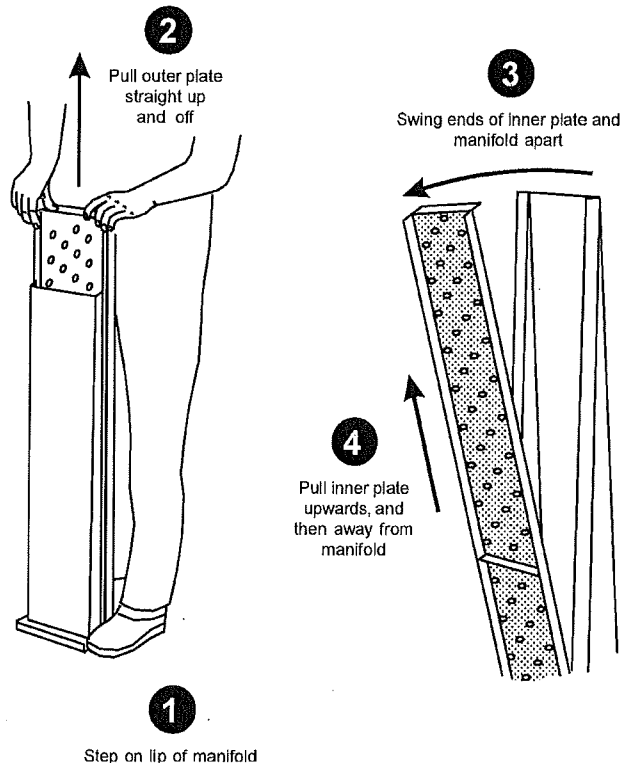
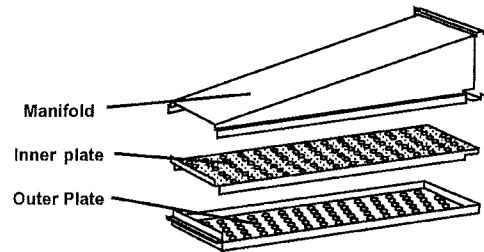

Figure 4-3. Disassembling the Air Fingers



III. MAINTENANCE – EVERY 3 MONTHS

- A. Check that the oven is cool and the power is disconnected, as described in the warning at the beginning of this Section.
- B. Vacuum both of the blower mounts, and their surrounding compartments, using a shop vacuum.
- C. Tighten all electrical terminal screws.
- D. **Split Belt Disassembly and Cleaning**
 1. Refer to Part D, Conveyor Installation, in the Installation section of this Manual. Then, remove the following components from the oven:
 - Conveyor end stop
 - Crumb trays
 - Chain cover
 - Drive chains
 - End plugs
 - Conveyor assembly
 2. Remove the master links from each conveyor belt. Then, roll the belts up along the length of the conveyor to remove them from the frame.
 3. Remove the two conveyor adjustment screws from the idler end of the conveyor frame, as shown in Figure 4-4.
 4. Remove the idler shaft assembly from the conveyor.
 5. Pull apart the two sections of the idler shaft.
 6. Clean the shafts thoroughly using a rag. Then, lubricate both the extended shaft and the interior of the hollow shaft using a light food-grade lubricant. **DO NOT** lubricate the shafts using WD40 or a similar product. This can cause the shafts to wear rapidly.
 7. Before reassembling the shafts into the conveyor frame, check that they are oriented properly.

Figure 4-4. Disassembling the idler shaft

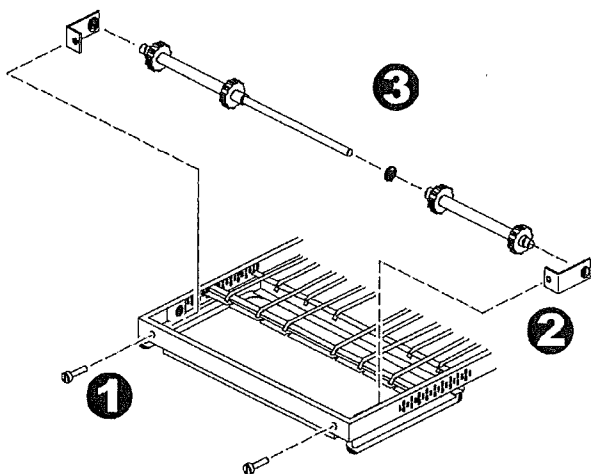

8. Reassemble the idler shaft into the conveyor. Make sure that the bronze washer is in place between the two sections of the shaft. See Figure 4-4.
9. Replace the conveyor adjustment screws as shown in Figure 4-4. To allow the conveyor belt to be reinstalled later, do not tighten the screws at this time.
10. Loosen the set screw on both of the conveyor drive sprockets. Then, remove the sprockets from the shaft.
11. Check the conveyor configuration as follows:

High-speed conveyors are equipped with large flange bearings at both ends of the shaft, as shown in Figure 4-5. For these conveyors, remove the two screws that hold each bearing to the conveyor frame. With the screws removed, lift the end of the shaft at the front of the oven, and pull the entire assembly free of the conveyor frame.

Standard conveyors are equipped with bronze bushings mounted on spacers at both ends of the shaft, as shown in Figure 4-5. For these conveyors, remove the two screws that hold the bracket to the conveyor frame. With the screws removed, lift the end of the shaft at the front of the oven, and pull the entire assembly free of the conveyor frame. The brackets will be removed along with the drive shaft assembly.
12. Disassemble and lubricate the two sections of the drive shaft as described for the idler shaft, above.
13. Before reassembling the shafts into the conveyor frame, check that they are oriented properly.
14. Reassemble the drive shaft into the conveyor. Make sure that the bronze washer is in place between the two sections of the shaft. See Figure 4-4.
15. Replace the drive sprockets. Reassemble the belts and master links onto the conveyor.
16. Reinstall the end plugs and conveyor onto the oven.
17. Reattach the drive chains. Replace the chain cover.
18. Check the tension of the conveyor belt as shown in Figure 2-14 (in Section 2, Installation). The belt should lift about 1" (25mm). If necessary, adjust the belt tension by turning the conveyor adjustment screws.
19. Replace all components onto the oven.

Figure 4-5. Drive shaft configurations

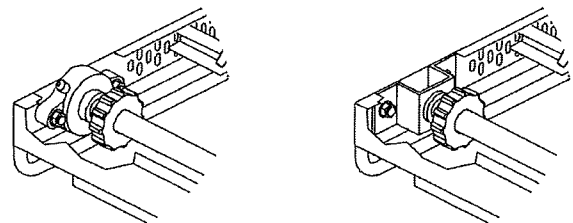

Figure 4-6. Disassembling the drive shaft

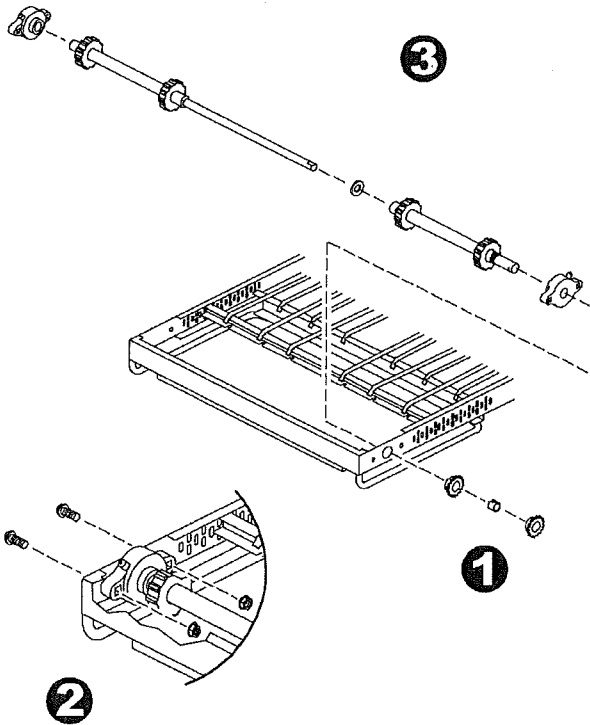
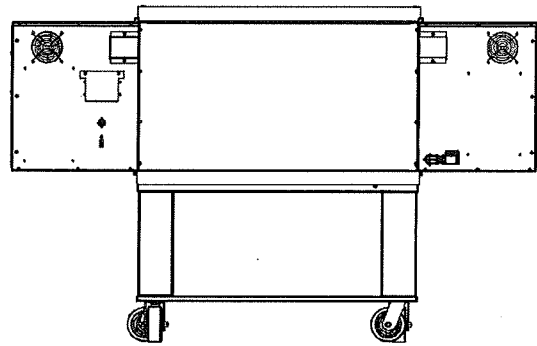

Figure 4-7. Rear panel access



E. Blower Belt

1. Remove the six screws shown in Figure 4-7. Then, remove the rear panel from the oven.
2. Check the blower belt for the proper 1/4" (6mm) deflection at the center, and for cracking or excessive wear.

See Figure 4-7. Overtightening the belt will cause premature bearing failure and possible vibrations. A loose belt may also cause vibrations.

3. If necessary, adjust the tension of the belt by loosening the four motor mounting bolts. Reposition the motor as necessary until the correct 1/4" (6mm) deflection is reached, then tighten the bolts.

IV. MAINTENANCE - EVERY 6 MONTHS

- A. Check that the oven is cool and the power is disconnected, as described in the warning at the beginning of this Section.
- B. For gas ovens, inspect and clean the burner nozzle and the spark electrode assembly.
- C. Check the conveyor drive shaft bushings and spacers. Replace the components if they are worn.

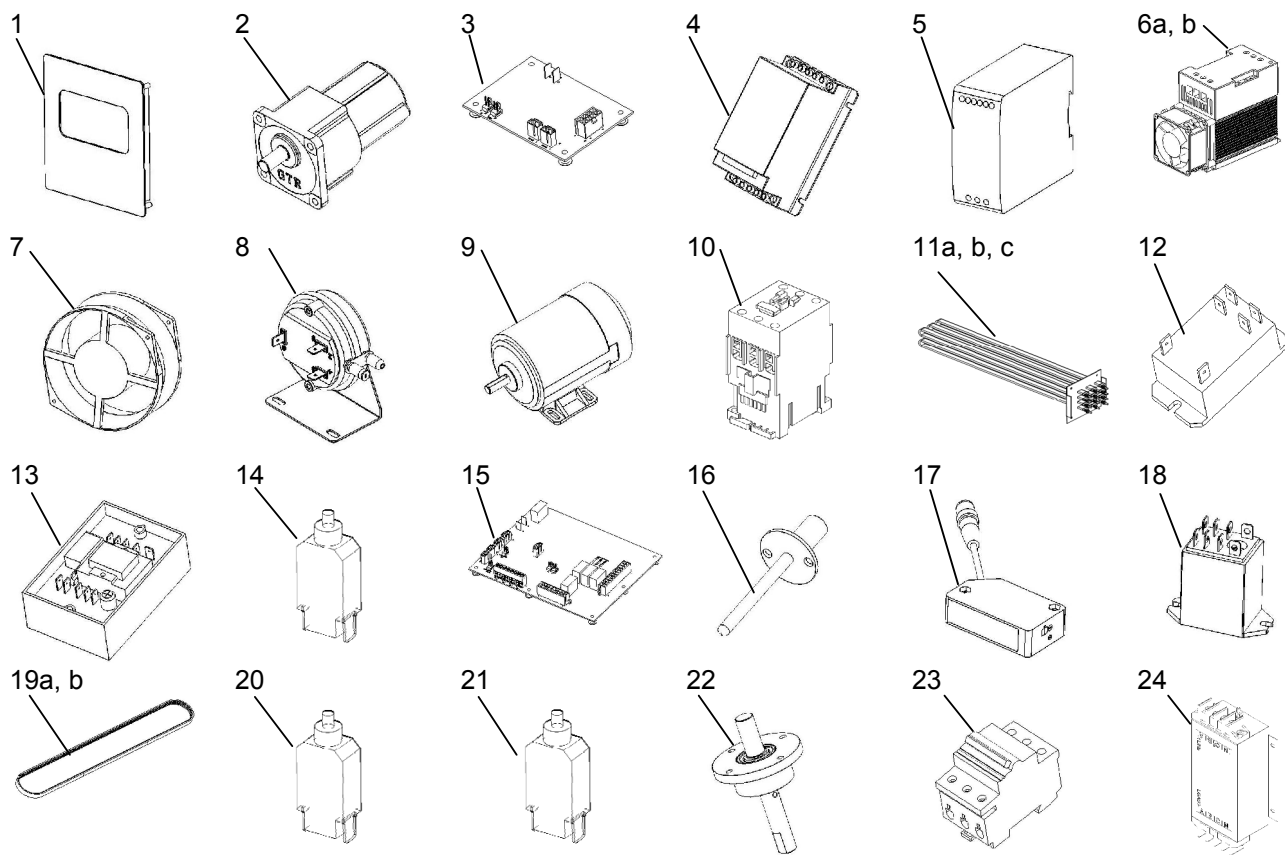

KEY SPARE PARTS PS636 ELECTRIC

ITEM	QTY	P/N	DESCRIPTION
1	1	65564	Digital Display, Programmed
2	1	65756	Motor, Conveyor Drive
3	1	65566	Conveyor Control Board
4	1	66065	Inverter, ½ HP (230V Input)
5	1	61186	Power Supply
6a	1	44914	Power Relay, 208-240V
6b		44568	Power Relay, 380-415V
7	1	36451	Fan,Cooling
8	2	62044	Air Switch
9	1	65701	Blower Motor, 3/8 HP
10	1	44549	Contactor
11a	1	68063	Heating Element, 208V, 19.8kW (400-415V)
11b	1	68064	Heating Element, 240V, 19.8kW
11c	1	68065	Heating Element, 380V, 19.8kW
12	1	50794	Relay, 30A (240V coil)
13	1	33983	Hi Limit Thermostat
14	1	45036	Circuit Breaker, 3A (Control Circuit)
15	1	65565	Board,Main – I/O
16	2	60520-2	Thermocouple, 2" Grounded
17	1	60185	Photo Sensor
18	1	59132	Relay, DPDT 24VDC Coil
19a	2	66381	Belt, Blower-to-Blower
19b	2	66382	Belt, Blower-to-motor
20	1	45644	Circuit Breaker, 1A (Conveyor Motors)
21	1	59206	Circuit Breaker, 10A (Blower Motors)
22	1	67043	Blower Bearing Assembly
23	1	45019	Circuit Breaker, 3-pole 63A
24	1	58131	RFI Filter, 50A (380V CE Only)

REV	DATE	ECN	REVISION DESCRIPTION	BY	CHK	DATE
A ₁	04/23/2012	A.1	NEW DRAWING		RVC	
A ₂	04/23/2012	A.2	ADDED 1-, 1-, V-, & V- WIRES TO I/O BOARD HARNESS TO MATE WITH 103 & 104.		RVC	
B	04/22/2012	012123	RELEASE FOR PRODUCTION		RVC AJ	02/08/2013

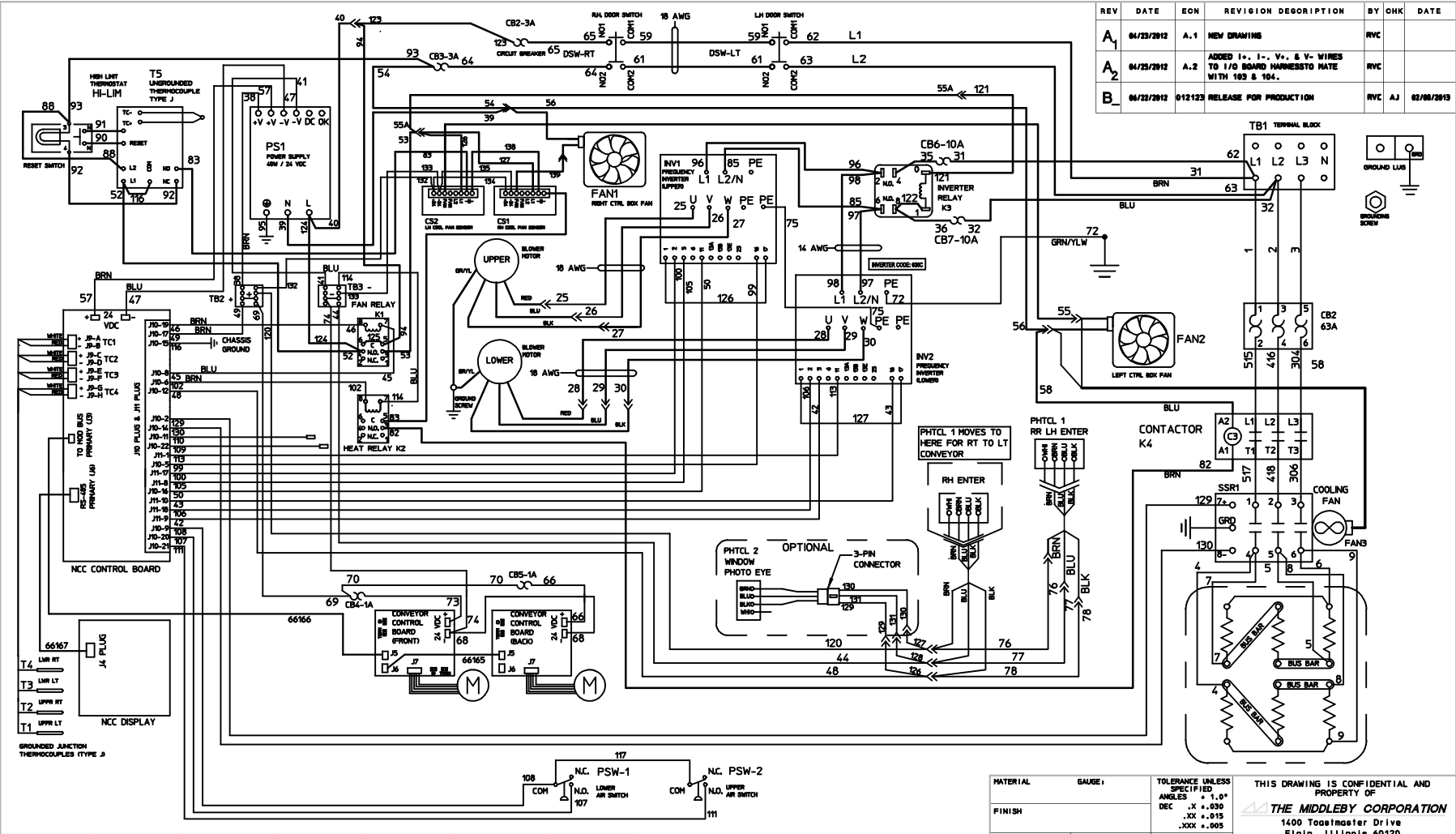

VOLTAGE	POWER	PHASE	L1	L2	L3	N
208	19.8 KW	3	57.2	57.2	55	NA
240	19.8 KW	3	49.6	49.6	47.6	NA

NOTE: WD LABEL P/N 68240

NOTES:
 ALL WIRE GAUGES TO BE 18 AWG UNLESS OTHERWISE SPECIFIED.
 C1 = 6 CIRCUIT AMP UML CONNECTOR.
 C2 = 12 CIRCUIT AMP UML CONNECTOR.
 □ = IN LINE BULB SPLICE.

MATERIAL	GAUGE:	TOLERANCE UNLESS SPECIFIED	THIS DRAWING IS CONFIDENTIAL AND PROPERTY OF THE MIDDLEBY CORPORATION 1400 Topeka Drive Elgin, Illinois 60120 847-741-3300
FINISH		ANGLE: +1.0° DEC: .XX +.030 .XXX +.005	
DRAWN RVC	CHECKED AJ	APPROVED AJ	
WD, E208-240 3PH PS636			
ALL DIMENSIONS ARE IN INCHES UNLESS OTHERWISE SPECIFIED.		PART NO 67990	SHT 1 OF 2
		REV B	

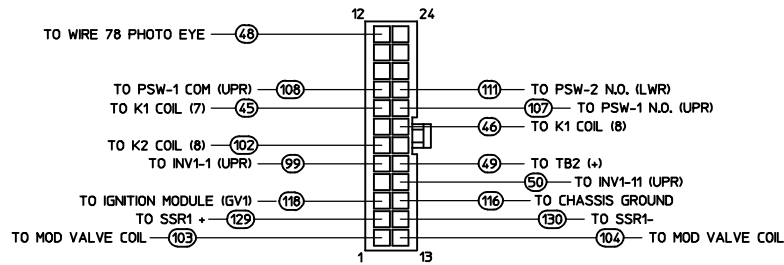

WIRES 103, 104 & 118 ARE ONLY USED ON GAS MODEL OVENS.
 WIRES 129 & 130 ARE ONLY USED ON ELECTRIC MODEL OVENS.
 CAP OFF WIRES (INDIVIDUALLY) WHEN NOT USED.

J10
 BACK OF PLUG
 (WIRE SIDE)

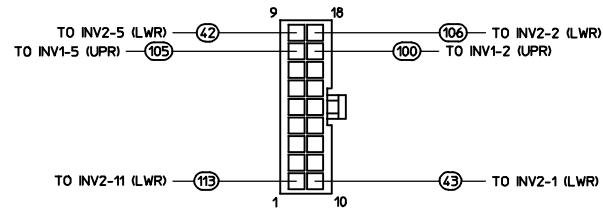

J11
 BACK OF PLUG
 (WIRE SIDE)

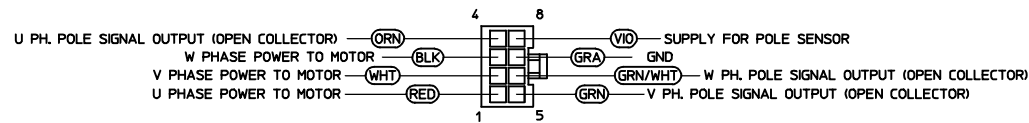

J7
 BACK OF PLUG
 (WIRE SIDE)
 BROTHER VGKC10

TOLERANCE UNLESS SPECIFIED ANGLES ± 1.0° DEC .X ± .030 .XX ± .015 .XXX ± .005	DRAWN RVC 04/22/2012	THIS DRAWING IS CONFIDENTIAL AND PROPERTY OF THE MIDDLEBY CORPORATION 1400 Toastmaster Drive Elgin, Illinois 60120 847-741-3300
	CHECKED AJ 02/08/2013	
	APPROVED AJ 02/08/2013	
WD, E208-240 3PH PS636		
ALL DIMENSIONS ARE IN INCHES UNLESS OTHERWISE SPECIFIED. DO NOT SCALE DRAWING	PART NO 67990	SHT 2 OF 2
		REV B

REV	DATE	ECN	REVISION DESCRIPTION	BY	CHK	DATE
A	08/01/2012	A.1	NEW DWS.		RVC	
B	08/01/2012	012136	RELEASE FOR PRODUCTION		RVC USS	08/17/2012

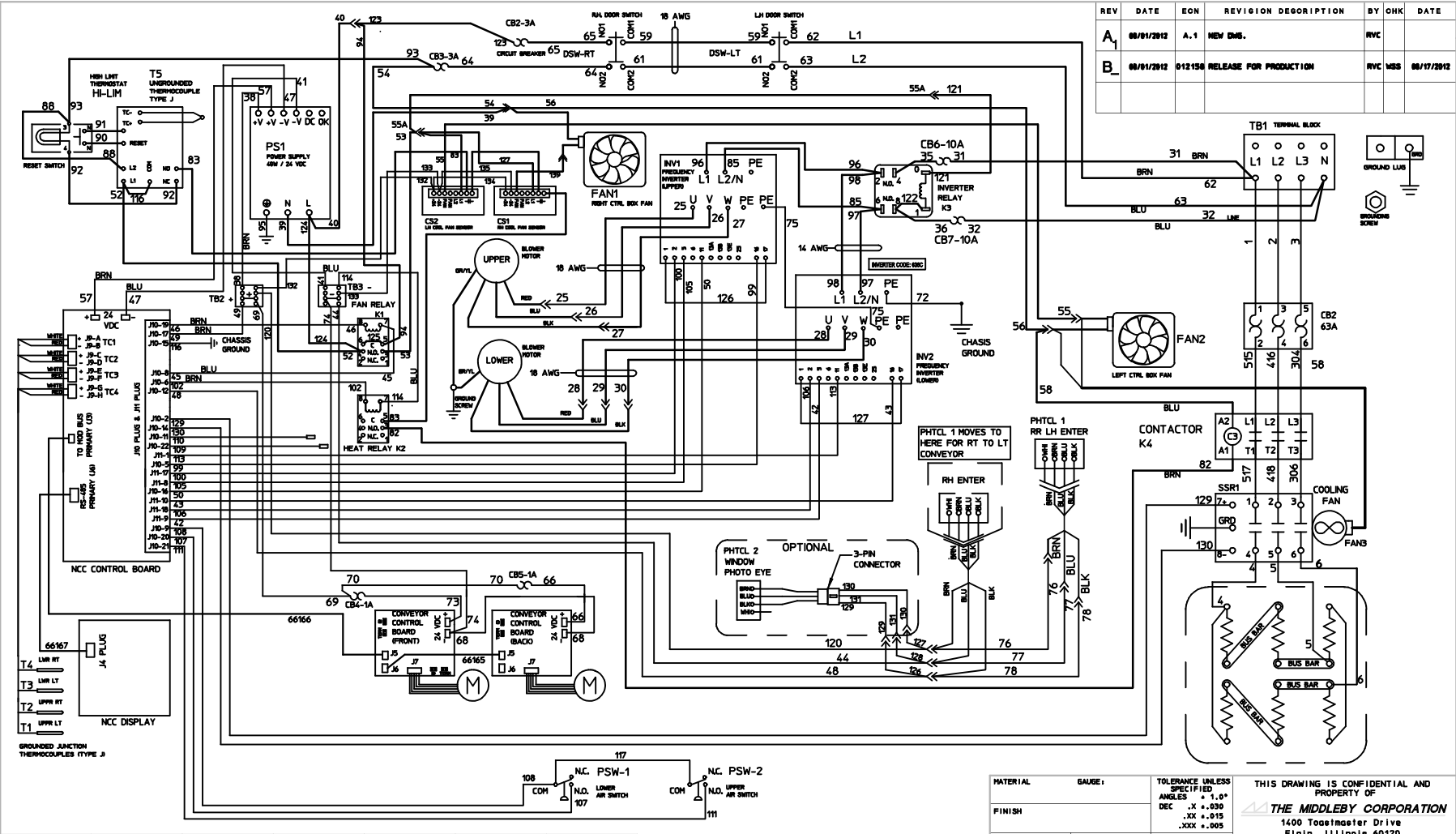

VOLTAGE	POWER	PHASE	L1	L2	L3	N
400	19.8 KW	3	30.6	28.6	28.6	2.0
415	19.8 KW	3	29.4	27.5	27.5	1.9

NOTE: WD LABEL P/N 68521

NOTES:
 ALL WIRE GAUGES TO BE 18 AWG UNLESS OTHERWISE SPECIFIED.
 C1 - 6 CIRCUIT AMP UML CONNECTOR.
 C2 - 12 CIRCUIT AMP UML CONNECTOR.
 □ - IN LINE BULB SPLICE.

MATERIAL	GAUGE:	TOLERANCE UNLESS SPECIFIED	THIS DRAWING IS CONFIDENTIAL AND PROPERTY OF THE MIDDLEBY CORPORATION 1400 Togetmaster Drive Elgin, Illinois 60120 847-741-3300	
FINISH		ANGLES ± 1.0° DEC .XX ± .030 .XXX ± .005		
DRAWN RVC 08/01/2012	CHECKED USS 08/17/2012	APPROVED USS 08/17/2012		
WD, E400-415V3PH PS636E				
ALL DIMENSIONS ARE IN INCHES UNLESS OTHERWISE SPECIFIED. DO NOT SCALE DRAWING		PART NO 68520	SHT 1 OF 2	REV B

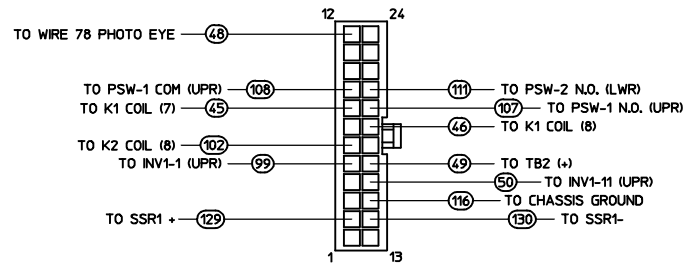

J10
BACK OF PLUG
(WIRE SIDE)

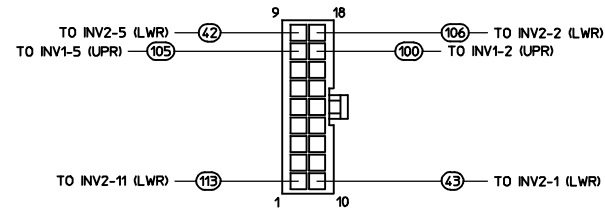

J11
BACK OF PLUG
(WIRE SIDE)

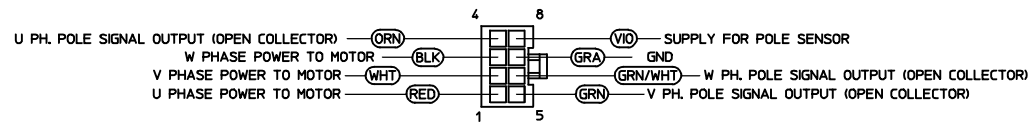

J7
BACK OF PLUG
(WIRE SIDE)
BROTHER VGKC10

TOLERANCE UNLESS SPECIFIED ANGLES ± 1.0° DEC .X ± .030 .XX ± .015 .XXX ± .005	DRAWN RVC 08/17/2012	THIS DRAWING IS CONFIDENTIAL AND PROPERTY OF THE MIDDLEBY CORPORATION 1400 Toastmaster Drive Elgin, Illinois 60120 847-741-3300
	CHECKED MSS 08/17/2012	
	APPROVED MSS 08/17/2012	
WD, E 400-415V3PH PS636E		
ALL DIMENSIONS ARE IN INCHES UNLESS OTHERWISE SPECIFIED. DO NOT SCALE DRAWING	PART NO 68520	SHT 2 OF 2
		REV B

REV	DATE	EON	REVISION DESCRIPTION	BY	CHK	DATE
B	02/08/2013	012123	RELEASE TO PRODUCTION	JM	AJ	02/08/2013

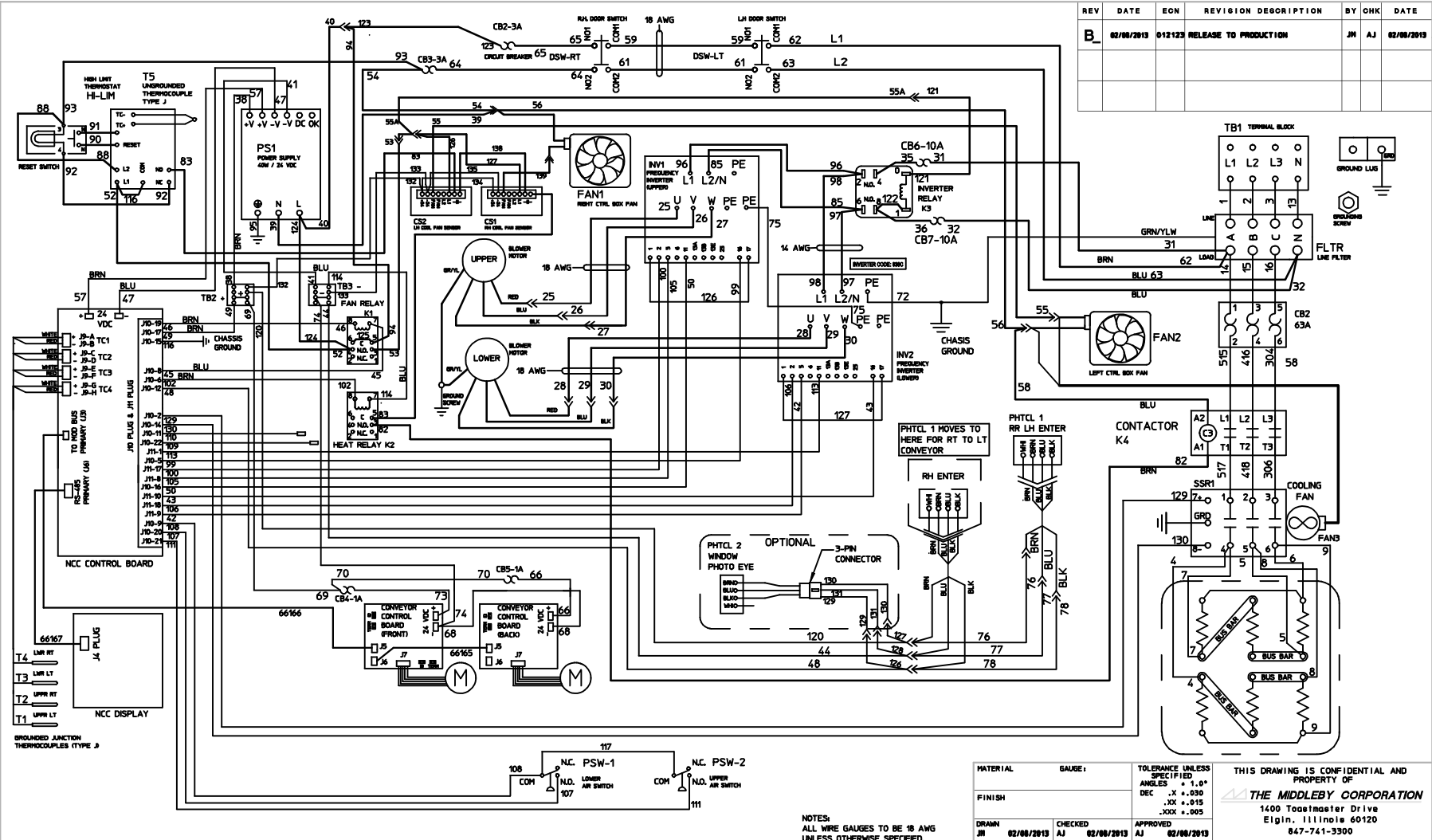

VOLTAGE	POWER	PHASE	L1	L2	L3	N
380	19.8 KW	3	32.1	30.1	30.1	2.0

NOTES: WD LABEL P/N 68583

NOTES:
 ALL WIRE GAUGES TO BE 18 AWG UNLESS OTHERWISE SPECIFIED.
 C1 = 6 CIRCUIT AMP UML CONNECTOR.
 C2 = 12 CIRCUIT AMP UML CONNECTOR.
 [Symbol] = IN LINE BUTT SPLICE.

MATERIAL	GAUGE:	TOLERANCE UNLESS SPECIFIED	THIS DRAWING IS CONFIDENTIAL AND PROPERTY OF THE MIDDLEBY CORPORATION 1400 Tugelmaster Drive Elgin, Illinois 60120 847-741-3300
FINISH		ANGLES ± 1.0° DEC .XX ± .030 .XX ± .015	
DRAWN JM	CHECKED AJ	APPROVED AJ	

WD, E380V PS636 CE

ALL DIMENSIONS ARE IN INCHES UNLESS OTHERWISE SPECIFIED. DO NOT SCALE DRAWING	PART NO 68581	SHT 1 OF 2	REV B
--	-------------------------	---------------	----------

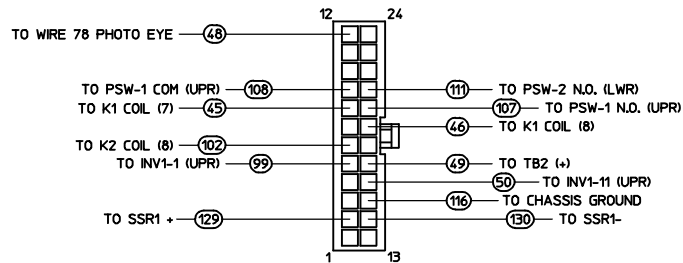

J10
BACK OF PLUG
(WIRE SIDE)

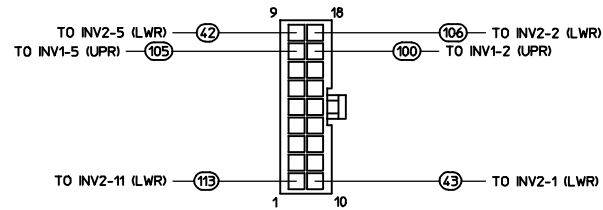

J11
BACK OF PLUG
(WIRE SIDE)

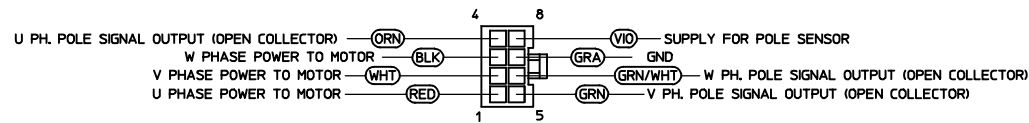

J7
BACK OF PLUG
(WIRE SIDE)
BROTHER VGKC10

TOLERANCE UNLESS SPECIFIED ANGLES ± 1.0° DEC .X ± .030 .XX ± .015 .XXX ± .005	DRAWN RVC 08/20/2012	THIS DRAWING IS CONFIDENTIAL AND PROPERTY OF THE MIDDLEBY CORPORATION 1400 Toastmaster Drive Elgin, Illinois 60120 847-741-3300
	CHECKED AJ 02/08/2013	
	APPROVED AJ 02/08/2013	
WD, E380V PS636 CE		
ALL DIMENSIONS ARE IN INCHES UNLESS OTHERWISE SPECIFIED. DO NOT SCALE DRAWING	PART NO 68581	SHT 2 OF 2
		REV B

REV	DATE	ECN	REVISION DESCRIPTION	BY	CHK	DATE
A	08/17/2012	A.1	NEW DMS		RVC	
B	08/20/2012	012123	RELEASE FOR PRODUCTION		RVC AJ	02/08/2013

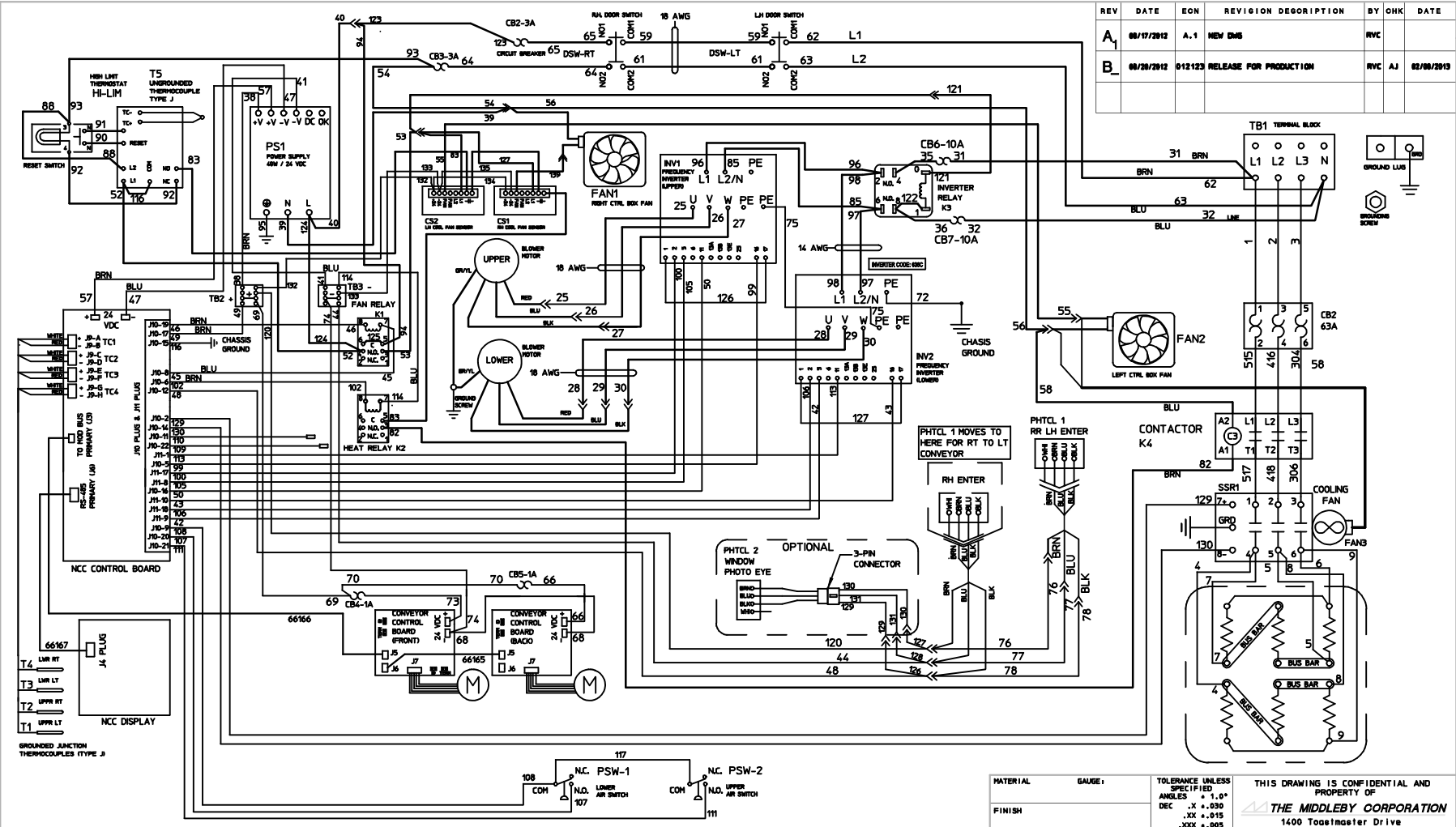

VOLTAGE	POWER	PHASE	L1	L2	L3	N
380	19.8 KW	3	32.1	30.1	30.1	2.0

NOTE: WD LABEL P/N 68584

NOTES:
 ALL WIRE GAUGES TO BE 18 AWG UNLESS OTHERWISE SPECIFIED.
 C1 = 6 CIRCUIT AMP UML CONNECTOR.
 C2 = 12 CIRCUIT AMP UML CONNECTOR.
 □ = IN LINE BUTT SPLICE.

MATERIAL	GAUGE:	TOLERANCE UNLESS SPECIFIED	THIS DRAWING IS CONFIDENTIAL AND PROPERTY OF THE MIDDLEBY CORPORATION 1400 Tosemaster Drive Elgin, Illinois 60120 847-741-3300	
FINISH		ANGLE: +1.0° DEC: .XX +.030 .XX +.015 .XXX +.005		
DRAWN RVC	CHECKED AJ	APPROVED AJ		
WD, E380V PS636 NON-CE				
ALL DIMENSIONS ARE IN INCHES UNLESS OTHERWISE SPECIFIED. DO NOT SCALE DRAWING		PART NO 68582	SHT 1 OF 2	REV B

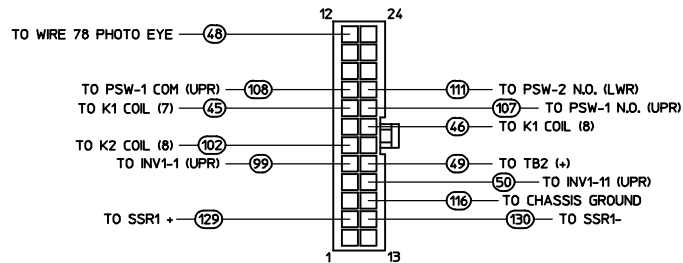

J10
BACK OF PLUG
(WIRE SIDE)

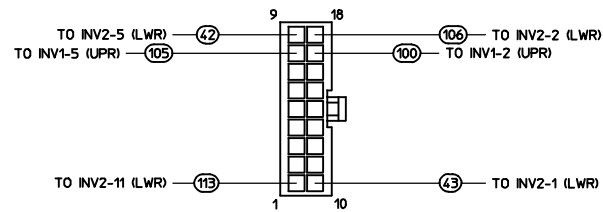

J11
BACK OF PLUG
(WIRE SIDE)

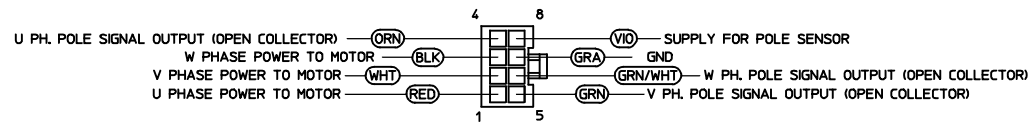

J7
BACK OF PLUG
(WIRE SIDE)
BROTHER VGKC10

TOLERANCE UNLESS SPECIFIED ANGLES ± 1.0° DEC .X ± .030 .XX ± .015 .XXX ± .005	DRAWN RVC 08/20/2012	THIS DRAWING IS CONFIDENTIAL AND PROPERTY OF THE MIDDLEBY CORPORATION 1400 Toastmaster Drive Elgin, Illinois 60120 847-741-3300
	CHECKED AJ 02/08/2013	
	APPROVED AJ 02/08/2013	
WD, E380V PS636 NON-CE		
ALL DIMENSIONS ARE IN INCHES UNLESS OTHERWISE SPECIFIED. DO NOT SCALE DRAWING	PART NO 68582	SHT 2 OF 2
		REV B

NOTES

NOTES

WARNING

Improper installation, adjustment, alteration, service or maintenance can cause property damage, injury or death. Read the installation, operating and maintenance instructions thoroughly before installing or servicing this equipment.

NOTICE

During the warranty period, ALL parts replacement and servicing should be performed by your Middleby Marshall Authorized Service Agent. Service that is performed by parties other than your Middleby Marshall Authorized Service Agent may void your warranty.

NOTICE

Using any parts other than genuine Middleby Marshall factory manufactured parts relieves the manufacturer of all warranty and liability.

NOTICE

Middleby Marshall reserves the right to change specifications at any time.

CFESA

Commercial Food Equipment Service Association

Middleby is proud to support the Commercial Food Equipment Service Association (CFESA). We recognize and applaud CFESA's ongoing efforts to improve the quality of technical service in the industry.

Middleby Cooking Systems Group • 1400 Toastmaster Drive • Elgin, IL 60120 • USA • (847)741-3300 • FAX (847)741-4406

www.middleby.com

